

Gottlieb
AMUSEMENT GAMES

165 W. Lake Street Northlake, IL 60164
(312) 562-7400 Telex 72-8463

A Columbia Pictures Industries Company



MAD PLANETS

Instruction Manual



MAD PLANETS (GAME GV-102) INSTRUCTION MANUAL (PRELIMINARY)

TABLE OF CONTENTS

SEC.		PAGE
I.	INSTALLATION	1
II.	INITIALIZATION	3
III.	GAME OPERATION	3
IV.	GAME PLAY AND SCORING	4
V.	SOUND	6
VI.	GAME ADJUSTMENTS/OPTIONS	6
VII.	BOOKKEEPING AND SELF TEST	7
VIII.	GENERAL INFORMATION	9
IX.	THEORY OF OPERATION	11
X.	WIRING AND SCHEMATIC DIAGRAMS	12

WELLS GARDNER MONITOR, SERVICE AND OPERATION MANUAL (Attached)

WARNING: This equipment generates, uses, and can radiate radio frequency energy and if not installed and used in accordance with the instructions manual, may cause interference to radio communications. It has been tested and found to comply with the limits for a Class A computing device pursuant to Subpart J of Part 15 of FCC Rules, which are designed to provide reasonable protection against such interference when operated in a commercial environment. Operation of this equipment in a residential area is likely to cause interference in which case the user at his own expense will be required to take whatever measures may be required to correct the interference."

NOTICE

WARRANTY INFORMATION IS LOCATED ON THE INSIDE BACK COVER.

FOR SERVICE, CALL TOLL FREE: 1-800-323-9121; (ILLINOIS) 1-800-942-1620

I. INSTALLATION



**MAD PLANETS
(GAME GV-102)**

I. INSTALLATION

A. SET—UP

1. Carefully inspect the exterior of the game for any damage which might have occurred during shipment.
2. Unlock and open the rear cabinet door.
3. Check that all plug in connectors are seated firmly. The connectors are keyed so they will only go in one way.
4. Remove the binding strap from the line cord, and install the line cord plate in the groove provided (see photo).
5. Cabinet levelers (2) are stored within the cash box for shipping purposes. Install and adjust as necessary.

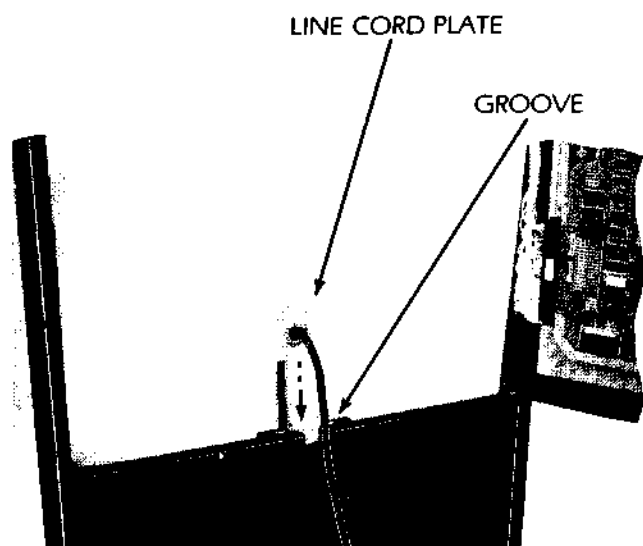

B. CHECK-OUT

1. Check that all cables are free of moving parts.
2. Check for any loose wires.
3. Check for loose solder or foreign matter on switches and power supply assemblies.
4. Be certain all fuses are seated firmly.
5. Be sure transformer wiring corresponds to the supply voltage.
6. Refer to section VI to make all the necessary game adjustments.
7. Reassemble the game.
8. Plug the line cord into a properly grounded 3-wire receptacle ONLY!!

C. CONTROL PANEL REMOVAL

1. Unplug the game.
2. Unlock and open the coin chute door.
3. Reach in through the coin chute door and remove the wing nut and flat washer from each of the two carriage bolts which secure the control panel to the game. Remove the carriage bolts.
4. Pull the control panel back, grasp it at the front edge as far back as it will go (approximately 1/4").
5. Raise the front of the control panel approximately one inch above its supports and lift the entire assembly high enough to disconnect plug A9J2/A9P2.
6. Remove the entire control panel assembly from the game.
7. The Joystick and leaf-switches are now accessible for removal or cleaning.

D. MONITOR REMOVAL

1. Unplug the game.
2. Perform the control panel assembly removal procedure (Section C).
3. Remove the outside shield, glass and monitor mask and put them aside in a secure place.
4. Unlock and open the rear cabinet door.
5. NOTE: The color monitor contains HIGH VOLTAGES delivering LETHAL quantities of energy. Do not attempt to service the monitor until you have shorted the anode plug on the picture tube to ground.
6. Disconnect the video plug A17J1, the monitor power supply plug A12J3/A12P3 and the ground wire from the monitor chassis.
7. From the rear of the game, remove the one nut and one washer from each of the four carriage bolts used to secure the monitor to the platform.
8. Remove the monitor from the rear of the game, being careful to clear all cables from the CRT neck.
9. For reassembly, reverse the above procedure.

II. INITIALIZATION, III. GAME OPERATION

II. INITIALIZATION

TURN GAME ON

Immediately, the coin chute lamps and the speaker marquee lamp will turn on.

AFTER A TEN SECOND DELAY

A. The attract mode appears on the screen.

B. The playing field cycles through the following:

1. High Game to Date screen
2. Instruction Set
3. Game Play Cycle

III. GAME OPERATION

A. GAME START

1. Insert coins into coin chute.
 - a. Coin chute tune is played.
 - b. Total credits are displayed on screen.
2. Press one or two player button to start game.
 - a. Demonstration scene displayed on screen.
 - b. Total Credits are decreased by one.
 - c. Game initializes.

B. FIRST PLAYER

1. The first player's score displays a zero.
2. The other player's display will be blank.

C. SECOND PLAYER

1. Additional player is indicated by the words "PLAYER 2" and a zero in the second player's display.

D. SHIPS/EXTRA SHIPS

1. Each player will begin with three ships (dependent on Option/Parameter settings).
2. Extra ships are earned by achieving certain score levels (dependent on Option/Parameter settings).

IV. GAME PLAY AND SCORING

HOW TO PLAY

The control panel consists of one or two player select buttons, a joystick with fire buttons and one rotary dial for rotating the ship. The players ship is moved vertically, horizontally or diagonally by the joystick. The ship can be rotated 360 degrees by the rotary dial. The fire buttons are located on the joystick, two on the front and one as a trigger style.

APPROACHING PLANETS — These planets first appear far in another galaxy and rapidly approach the players ship. They do not have moons orbiting around them. The player is awarded 100 points for destroying an Approaching Planet.

ATTACKING PLANET — A planet that has three to six moons orbiting around it. An attacking Planet seeks out and tries to destroy the players ship by colliding with the ship or releasing moons into space. An Attacking Planet cannot be destroyed until all of the orbiting moons have been destroyed (see MAD PLANET). An Attacking Planet scores 1 point when hit.

ORBITING MOON — These are moons that are in orbit around the Attacking Planet. Destroying an Orbiting Moon awards 10 points.

MAD MOON — Any moon that leaves its original orbit around the planet and is free floating in space. These orange moons must be avoided or destroyed. Destroying a Mad Moon scores 100 points and is eliminated from the planet that released it. If the Mad Moon escapes the player and moves off the screen, it is replaced in its original orbit around the Attacking Planet.

MAD PLANET — Commencing with the destruction of all of the Orbiting Moons, an Attacking Planet transposes into a Mad Planet. A Mad Planet must be destroyed quickly as its vengeful quest to destroy the ship causes its movement to quicken rapidly. Mad Planets score 200, 300 or 500 points, dependent on its size.

COMETS — Comets first appear in the beginning of the third round and continue throughout the game. They travel indiscriminately around the planets and are deadly to the players ship. It must be avoided or destroyed. The first Comet destroyed awards 100 points. Every Comet destroyed in succession increments its value by 100 points up to 1000 points awarded for the tenth and all following Comets. However, if a Comet is allowed to leave the screen at any time during the round, the Comet values start over at 100 points

and repeat the scoring sequence. This scoring sequence repeats at the beginning of each new round.

HUMANS — Humans first appear in the first Bonus Period (see BONUS PERIOD) and all subsequent rounds thereafter. Humans are picked up by the players ship by touching them with the ship. Points awarded for picking up Humans advances for each wave of game play. Starting with the second wave, Humans award 300 points each. This increments by 100 points for each subsequent wave to a maximum of 1000 points per Human in the ninth wave and remains at 1000 points for the remainder of the game. During a Bonus Period, all Humans score 200 points (see BONUS PERIOD).

BONUS PERIOD — A Bonus Period is achieved at the end of each wave (see ROUND PROGRESSION). During the Bonus Period only the players ship, Humans and Comets appear on the screen. The Player must pick up Humans to gain bonus points and avoid being hit by the Comet. The period ends when either the players ship is destroyed by a Comet, the Comet is allowed to leave the screen or ten Comets have been destroyed. Each Comet appearing (up to ten) must be destroyed for the Bonus Period to continue. Comets score 100 points for the first one destroyed and increment by 100 points for each subsequent Comet that is eliminated. All Humans score 200 points during the Bonus Period.

PERFECT ROUND — A Perfect Round is achieved by destroying all of the planets in a round while they are Approaching Planets. They must not be allowed to form into Attacking Planets and the players ship must not be destroyed. A Perfect Round awards the total number of Attacking Planets allowed to appear on the screen at one time for that round times 2000.

GAME PLAY

Game play is initiated when either the one player or two player buttons are pressed. As the round begins, Approaching Planets from a distant galaxy begin to approach the players ship. The player has the option of destroying the planets as they are approaching him. Successfully destroying all Approaching Planets in a round awards bonus points for a Perfect Round. When a planet is allowed to reach the players ships orbit, it reveals a group of moons orbiting around it. This becomes an Attacking Planet. An Attacking Planet cannot be destroyed until the player has destroyed all of

IV. GAME PLAY AND SCORING

its Orbiting Moons. Once all of the Orbiting Moons have been destroyed, the planet transposes into the Mad Planet destined to destroy the player's ship. The Mad Planet must be destroyed quickly as it travels faster and faster the longer it remains in orbit.

Each round has a predetermined number of planets per round and a predetermined number of Attacking Planets to fight at one time (see ROUND PROGRESSIONS). Once an Attacking Planet is destroyed, another planet approaches. If not destroyed, it also will become an Attacking Planet. This cycle continues until there are no longer any planets to destroy in that round. Once all the planets have been destroyed, the game advances to the next round.

In defense to the player's attack, the Attacking Planet will release one of its Orbiting Moons into space in an attempt to destroy the player's ship. This orange moon must be avoided or destroyed. If the Mad Moon is allowed to leave the screen without being destroyed, it is replaced in its original orbit around the Attacking Planet that released it.

The Bonus Period appears at the end of each wave. During this time, the player must pick up Humans while trying to destroy as many Comets as possible. The period ends when either the player's ship is destroyed by a Comet, the Comet is allowed to leave the screen or ten Comets have been destroyed (see BONUS PERIOD).

ROUND PROGRESSIONS

ROUND #	NUMBER OF ATTACKING PLANETS	TOTAL NUMBER OF PLANETS IN ROUND	HUMAN POINTS	PERFECT ROUND BONUS	WAVE
1	2	5	—	4000	1
2	3	6	—	6000	
3	4	7	—	8000	
BONUS PERIOD			200		
4	2	8	300	4000	2
5	3	9	300	6000	
6	4	10	300	8000	
BONUS PERIOD			200		
7	2	11	400	4000	3
8	3	12	400	6000	
9	4	13	400	8000	
BONUS PERIOD			200		
10	2	14	500	4000	4
11	3	15	500	6000	
12	4	16	500	8000	
BONUS PERIOD			200		
13	2	17	600	4000	5
14	3	18	600	6000	
15	4	19	600	8000	
16	5	20	600	10,000	
BONUS PERIOD			200		
17	2	20	700	4000	6
18	3	20	700	6000	
19	4	20	700	8000	
20	5	20	700	10,000	
BONUS PERIOD			200		
21	2	20	800	4000	7
22	3	20	800	6000	
23	4	20	800	8000	
24	5	20	800	10,000	
BONUS PERIOD			200		
25	2	20	900	4000	8
26	3	20	900	6000	
27	4	20	900	8000	
28	5	20	900	10,000	
BONUS PERIOD			200		
29	2	20	1000	4000	9
30	3	20	1000	6000	
31	4	20	1000	8000	
32	5	20	1000	10,000	
BONUS PERIOD			200		

ROUNDS 29 THROUGH 32 ARE REPEATED FOR ROUNDS 33 THROUGH 99

V. SOUND, VI. GAME ADJUSTMENTS / OPTIONS

V. SOUND

The Sound Board installed in this game has been programmed for sound only. The switch bank on the Sound Board is not used and the switch positions have no effect on the sound.

VI. GAME ADJUSTMENTS/OPTIONS

A. CONTROL BOARD SWITCH ADJUSTMENTS

SWITCH 1 **DEMONSTRATION MODE***
ON DEMO MODE
OFF NORMAL PLAY

SWITCH 2 **ATTRACT PLAY**
ON NO SOUND
OFF SOUND

SWITCHES
3 4 **CREDITS/COINS**
ON ON FREE PLAY
OFF ON 1/2
ON OFF 2/1
OFF OFF 1/1

SWITCH 5 **SHIPS**
ON 5
OFF 3

SWITCH 6 **FREE SHIPS**
ON EVERY 12,000 POINTS
OFF EVERY 10,000 POINTS

SWITCHES
7 8 **DIFFICULTY CONTROL**
ON ON VERY HARD
OFF ON HARD
ON OFF EASY
OFF OFF STANDARD

*IN THE DEMONSTRATION MODE THE PLAYER CAN SELECT ANY ROUND BY ROTATING THE ROTARY DIAL. EXTRA SHIPS ARE OBTAINED BY DEPRESSING THE ONE PLAYER START BUTTON. GAME PLAY IS INITIATED BY DEPRESSING THE TWO PLAYER START BUTTON.

B. SOUND ADJUSTMENTS

The audio output is controlled by the potentiometer mounted on the service panel assembly (located inside the coin mechanism door).

Turning the potentiometer counter-clockwise will decrease the volume. Turning it clockwise will increase the volume.

IMPORTANT. Each of the potentiometers installed on the Sound board have been factory adjusted. The potentiometer settings should never be changed when performing the recommended calibration procedure.

C. MONITOR ADJUSTMENTS

Normally, few if any adjustments are required for proper monitor operation. However, after any major repairs to the monitor chassis refer to the attached monitor manual.

VII. BOOKKEEPING AND SELF TEST

POWER UP

Upon power up, this game will check ROM's 0 through ROM 4 and RAM's 0, 1 and 2 for integrity. If any of the ROM's check sums are incorrect, the screen will display a warning and display the defective ROM(s). If any of the RAM's are defective, the screen will display the message "DEFECTIVE RAM." These messages will stay on the screen until both the one player and two player start buttons are depressed simultaneously. In such a case, the game may not perform properly. When both the ROM's and RAM's check good, no message is displayed.

After the memory test sequence, the screen will display "PRESS FIRE FOR START OF NEW DAY, CLEAR ULTRA SCORES," for ten seconds. If the fire button is pressed during this time, the computer recognizes a new day (see USAGE TABLE) and resets the Ultra High Score table. If the button is not pressed during this time, the computer assumes continuation of the same day and the Ultra Scores are retained. NOTE: There are two high score tables: The Ultra High Score table (daily high scores), and the Galactic Hall of Fame table (all time high scores). The Galactic Hall of Fame table can be reset during Self Test 3.

SELF TEST

The battery back-up bookkeeping functions of this game are contained in Self Test steps 3 and 4. These are in addition to the electro-mechanical coin counter located inside the front door panel. Every time a coin is inserted into a coin slot, the counter is energized, incrementing the count.

The self-test consists of six functions which may be used to identify problems in the video system and to change program parameters.

The self-test mode is entered by setting the self-test toggle switch located inside the cash door to "TEST". A selection of available tests is displayed on the monitor. To return to the GAME mode at any

time, the operator needs only to set the toggle switch back to "GAME".

Selection of tests is done with the push button switch labeled "SELECT". Upon entering the test mode, a flashing arrow points to the first test selection. Momentarily depressing the "SELECT" button will advance through each selection one by one.

When the arrow is pointing to the desired test, the operator may begin that test by pressing the "SELECT" button and holding it down until the test appears on the screen.

Once a test has been selected, the operator can return to the selection list by holding down the select switch until it re-appears. The seven tests are as follows:

1. MONITOR ADJUSTMENT

Three patterns can be displayed on the screen for adjusting monitor color, brightness, contrast and convergence. The patterns are: Color scale, a gray scale, and a dot pattern. By momentarily pressing the select switch, the operator may cycle through the three patterns.

2. DIP SWITCHES

A functional description of the eight Dip Switches located on the Logic Board Assy. is displayed. Changing any switch will cause an immediate update of the description displayed on the screen.

3. BOOKKEEPING

Selecting this test will display a menu of four functions. Pushing the SELECT button momentarily will move an arrow on the screen. When the arrow points to the desired function, press either start button on the control panel to perform that function.

DISPLAY SCORE COUNTS — A table is shown with 20 categories of score values by thousands (K) and a count associated with each category. The count represents the number of plays in which the score at the end of the game fell into that category. In addition, a high score, low score, and average is shown along with the total number of plays on which the average is based. To clear the table, press either start button and return to the menu by holding down SELECT.

VII. BOOKKEEPING AND SELF TEST

DISPLAY TIME COUNTS — Same as above except each category represents play times in minutes. The high, low, and average are given in minutes and seconds.

DISPLAY ROUND COUNTS — Same as above except each category represents the round in which the games ended.

Note: Each of these tables is independent of the others. Any table may be cleared without affecting the others in any way.

RESET HALL OF FAME — Pressing either start button will reset the Hall of Fame table (all time high scores).

CLEAR COIN COUNT — The number to the right of COINS COLLECTED is set to zero. The hardware coin counter is not affected. This number will always be the number of coins collected since the last time the count was cleared.

4. USAGE TABLE

This table is an extension of the bookkeeping sections vital statistics. It shows the performance of this machine from the standpoint of how busy this machine was servicing customers (or how much idle time there was). Since the machines usage depends heavily upon the time of day, the percentage of usage (50% for 30 minutes busy, 30 minutes idle) is based on an hourly basis. If the machine was being played most of the time during the hour, it may show a figure close to 99%.

The table gives the previous one weeks usage data. The column displaying -1 shows yesterdays data, the column displaying -2 shows the day before, etc. Only 16 hours of data can be displayed on the table for one day. If the machine is kept on for more than 16 hours, the overflowed data will be automatically placed under the next days data.

When a power interruption is detected during an hour, an asterisk sign is attached next to the percentage value indicating the particular hour may have actually been much longer.

This machine has no internal clock to keep track of the exact time or day. It can only keep track of how much time has passed like a stopwatch. In order for this machine to distinguish between a power up of a new day

from a power up of a middle-of-the-day servicing, an operators input is required. To tell the machine that a power up is the beginning of the day, the operator must press the fire button within ten seconds of the power up. This practice ensures the usage tables data to be tabulated by the day of the week, and at the same time clears today's high scores (Ultra Scores). See POWER UP for this sequence.

5. MEMORY

For each RAM memory chip: An OK or an NG (no good) appears signaling that the chip is good or bad respectively.

For each ROM memory chip: the same OK or NG applies in addition to the respective check sums being displayed. If you have a suspect ROM, refer to your distributor for the correct check sum number.

6. SWITCHES

A colored square is displayed for each player button. Pressing a button causes the appropriate square to change color.

For each coin mechanism, a digit is displayed (initially 0). Inserting a coin into a coin chute will increment the appropriate value without affecting the coin meter.

Moving the joystick will display its direction of movement by the fire buttons colored square. The rotary dial input is also tested for both rotations.

7. SOUND TEST

After selecting this test a count will appear on the screen representing the various sounds that are produced by the game. There will be 20 different sounds produced and the screen count will repeat to 01. Pressing either Start button will suppress all sound output and speed up the count so a particular sound can be sought out and checked.

Note: The count on the screen represents the binary signal code that will be sent to the A6 Sound board through the six sound input lines on the A6J1 connector. When executing the Sound Test sequence, there will be no sounds produced on counts 16 and 22 thru 41. There are no sounds assigned to these numbers.

VIII. GENERAL INFORMATION

A. PRINTED CIRCUIT BOARDS ARE DESIGNATED AS FOLLOWS:

- A1 Logic Board Assy.
- A2 Interface Assy.
- A3 Power Supply Assy.
- A6 Sound Board Assy.
- A8 Filter Board

B. WIRE COLORS ARE SHOWN AS NUMBERS:

0 Black	5 Green
1 Brown	6 Blue
2 Red	7 Purple
3 Orange	8 Slate
4 Yellow	9 White

For example, 688 is a BLUE- SLATE-SLATE striped wire.

C. FUSES

BOTTOM PANEL

F1	Primary Power	4 Amp SLO-BLO
F2	6.3 VAC	3 Amp SLO-BLO
F3	Monitor	2 Amp SLO-BLO
F4	9 VAC	10 Amp SLO-BLO
F5	15 VAC	1 Amp SLO-BLO

POWER SUPPLY ASSY. (A3)

F11	+5VDC Source	5 Amp SLO-BLO	
F21	Sound Board Assy.	+30VDC	2 Amp SLO-BLO
F31	Sound Board Assy.	+12VDC	¼ Amp SLO-BLO
F32	Sound Board Assy.	-12VDC	¼ Amp SLO-BLO
F41	Coin Meter	+20VDC	1 Amp SLO-BLO

VIII. GENERAL INFORMATION

POWER SUPPLY SPECIFICATIONS

LOCATION	VOLTAGE	PROTECTION
Logic Board Assy.	+5VDC	Voltage adjustable. 6Amps over-voltage protection and fused for over-current protection.
Sound Board	+30VDC	2 Amps fused for over-current protection. The reference for this circuit is a 1N5363 + 30VDC Zener controlling the base of an emitter follower pass transistor.
Sound Board	+12VDC -12VDC	100 milliamps fused for over-current protection. The plus and minus 12 volts supplies are the 7812 and 7912 IC regulators respectively.
Coin Meter	+20VDC	Full wave rectified unfiltered voltage, fused for over-current protection.
Coin Chute Lights	+4.5VDC	Full wave rectified unfiltered voltage, fused for over-current protection.
Monitor and Marquee	100VAC or 115VAC, 60HZ	Isolated, fused AC voltage.

IX. THEORY OF OPERATION

INTRODUCTION

The character based graphics system designated GG-III has two main subdivisions. The first subdivision is the Central Processor Unit (CPU) which has three partitions:

- a. Microprocessors
- b. Memory
- c. Input and Output ports (I/O)

The Intel 8088 microprocessor is used and 32K bytes of memory is reserved for programming space and has 5 input ports and 5 output ports. The second subdivision is the video state machine which generates and controls the video signal to the monitor. The state machine has three partitions:

- a. System Clock (CLK)
- b. Foreground generator (FGND)
- c. Background generator (BGND)

The system clock is driven by a 20MHZ crystal, divided down for a 5MHZ dot clock.

All inputs and outputs including the video control and general purpose I/O are memory-mapped, (i.e. everything within the system can be addressed in a single segment of 64K addresses as memory).

The video control unit is divided into an "object-oriented" foreground driver and "character-oriented" background driver. The screen resolution is 256 pixels horizontally, and 240 lines vertically for both foreground and background. The CPU communicates with the foreground driver and background driver by writing data into the

designated memory areas in a certain format. The foreground is designed to display moving objects on the screen with a minimum overhead to the processor. The game programs will only have to specify the vertical and horizontal position and the object select number to the foreground driver. The background video supplements the foreground with relatively static figures on the screen. The CPU specifies all the character positions on the screen with desired "character" patterns.

A 5MHZ system clock drives a 9 bit horizontal dot counter and an 8 bit vertical line counter. The horizontal counter counts from 0 to 255 during active scan line and 256 to 317 during horizontal blanking time. When the horizontal counter reaches 317, the horizontal counter resets to 0. At the beginning of the horizontal blanking time (horizontal counter = 256) it increments the vertical counter. The vertical counter counts from 0 to 239 during active vertical scan time and 240 to 255 during vertical blanking time.

The battery backup system supports two battery RAM's that store all of the bookkeeping functions. The battery is maintained at a +3.6V reference by a trickle charge supplied on the logic board regulated by a current limiting resistor. If the AC power to the game is interrupted, the battery allows the RAM's to store the data contained in the Distributors table and the Options/Parameters screen.

X. WIRING AND SCHEMATIC DIAGRAMS, PARTS LISTS

TABLE OF CONTENTS

	PAGE
LOGIC BOARD ASSY. (A1)	
COMPONENT LOCATION AND PARTS LIST	13
SCHEMATIC DIAGRAM (SHEET 1 OF 3)	16
SCHEMATIC DIAGRAM (SHEET 2 OF 3)	18
SCHEMATIC DIAGRAM (SHEET 3 OF 3)	21
POWER SUPPLY ASSY. (A3)	
COMPONENT LOCATION AND PARTS LIST	24
SCHEMATIC DIAGRAM	25
SOUND BOARD ASSY. (A6)	
COMPONENT LOCATION AND PARTS LIST	27
SCHEMATIC DIAGRAM	28
PRIMARY POWER/FILTER BOARD/ INTERCONNECTION DIAGRAM	30
INTERFACE ASSY. (A2)	
SCHEMATIC DIAGRAM	33
COMPONENT LOCATION AND PARTS LIST	34

X. WIRING AND SCHEMATIC DIAGRAMS, PARTS LISTS

LOGIC BOARD ASSY. (A1), COMPONENT LOCATION

LOGIC BOARD ASSY. (A1), PARTS LIST

MISCELLANEOUS ELECTRONIC COMPONENTS

REFERENCE	DESCRIPTION	PART NO.
Bat. 1	Battery, 3.6V	XO-458
C1-C16	Capacitor, 0.1 UF 50V AX. CR. +80%-20%	XO-230
C25	Capacitor, 100 UF, 25V EL-AX	XO-212
C26	Capacitor, 0.1 UF, 50V AX. CR. +80%-20%	XO-230
C27	Capacitor, 100 UF, 25V EL-AX	XO-212
C31-34	Capacitor, 0.1 UF, 50V AX. CR. +80%-20%	XO-230
C51	Capacitor, 100 PF, 100V CMD 5%	XO-198
C52	Capacitor, 0.1 UF, 100V CMD 5%	XO-196
ALL UNMARKED CAPACITORS	01 UF, 50V AX. CR. +80%-20%	XO-229
ALL POLARIZED UNMARKED CAPACITORS	10 UF, 25V AX. TANT. 10%	XO-127
D2	Diode, 1N4454	XO-275
D4	Diode, 1N4733A	XO-274
DB1	Diode, 1N4148	XO-261
O1-O4	Transistor, 2N6044	XO-120
OB1-OB7	Transistor, MPSA70	XO-309
R1-R16	Resistor, 470 OHM, 5% 1/4W	XO-35
R37, R38	Resistor, 330 OHM, 5% 1/4W	XO-34
R39	Resistor, 130 OHM, 5% 1/4W	XO-172
R40	Resistor, 270 OHM, 5% 1/4W	XO-68
R41, R42	Resistor, 510 OHM, 5% 1/4W	XO-25
R43	Resistor, 130 OHM, 5% 1/4W	XO-172
R44, R45	Resistor, 1K OHM, 5% 1/4W	XO-5
R51, R52	Resistor, 330 OHM, 5% 1/4W	XO-34
R53, R54, R56	Resistor, 1K OHM, 5% 1/4W	XO-5
R57, R58	Resistor, 560 OHM, 5% 1/4W	XO-36
R59-R61	Resistor, 1K OHM, 5% 1/4W	XO-5
R63, R64	Resistor, 1K OHM, 5% 1/4W	XO-5
R70	Resistor, 1K OHM, 5% 1/4W	XO-5
R73, R74	Resistor, 1K OHM, 5% 1/4W	XO-5
R76-R80	Resistor, 1K OHM, 5% 1/4W	XO-5
R81	Resistor, 820 OHM, 5% 1/4W	XO-174
R82	Resistor, 100 OHM, 5% 1/4W	XO-28
R83, R84	Resistor, 15 OHM, 5% 1/4W	XO-171
R85	Resistor, 180 OHM, 5% 1/4W	XO-24
R86, R87	Resistor, 15 OHM, 5% 1/4W	XO-171
R88	Resistor, 180 OHM, 5% 1/4W	XO-24
R89, R90	Resistor, 15 OHM, 5% 1/4W	XO-171
R91	Resistor, 180 OHM, 5% 1/4W	XO-24
R92	Resistor, 1K OHM, 5% 1/4W	XO-5
R93	Resistor, 2K OHM, 5% 1/4W	XO-14
R94	Resistor, 1K OHM, 5% 1/4W	XO-5
R95	Resistor, 470 OHM, 5% 1/4W	XO-35
R96	Resistor, 240 OHM, 5% 1/4W	XO-173
R97	Resistor, 2K OHM, 5% 1/4W	XO-14
R98	Resistor, 1K OHM, 5% 1/4W	XO-5
R99	Resistor, 470 OHM, 5% 1/4W	XO-35
R100	Resistor, 240 OHM, 5% 1/4W	XO-173
R101	Resistor, 2K OHM, 5% 1/4W	XO-14
R102	Resistor, 1K OHM, 5% 1/4W	XO-5
R103	Resistor, 470 OHM, 5% 1/4W	XO-35
R104	Resistor, 240 OHM, 5% 1/4W	XO-173
SIP 1, SIP 2, SIP 4	Resistor, Dip, 4.7K, 9 Pin	XO-492
SIP 71, SIP 72, SIP 73	Resistor, Dip, 1K, 9 Pin	XO-493
X-TAL 1	Crystal, 15 MHZ	XO-482
XTAL 51	Crystal, 20 MHZ	XO-494
	Dip Switch	XO-505
	20 Pin Dip Socket	XO-491
	22 Pin Dip Socket	XO-467
	24 Pin Dip Socket	XO-529
	28 Pin Dip Socket	XO-536
	40 Pin Dip Socket	XO-530

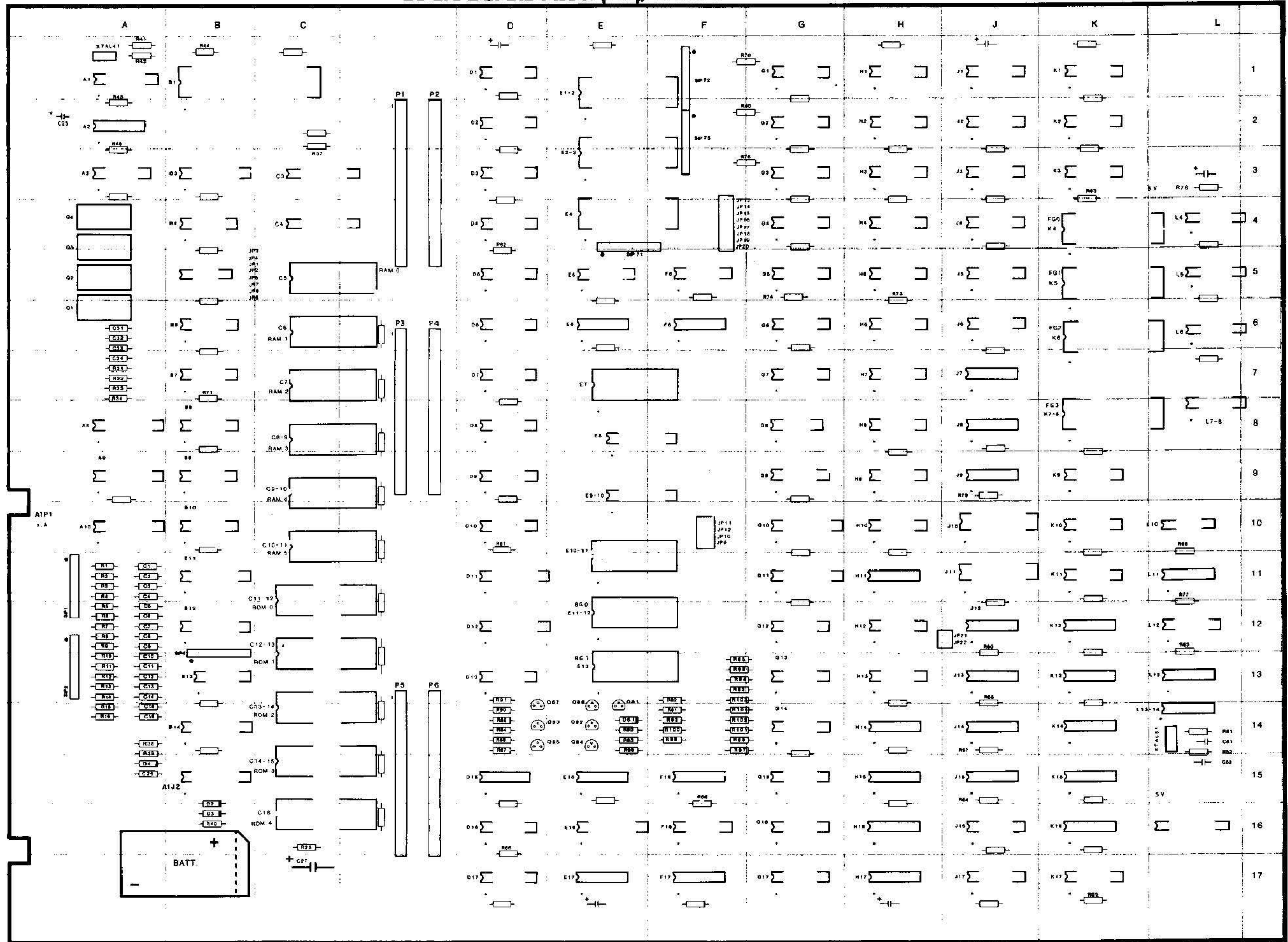

X. WIRING AND SCHEMATIC DIAGRAMS, PARTS LISTS

LOGIC BOARD ASSY. (A1), PARTS LIST (CONT.)

REFERENCE	DESCRIPTION	PART NO.	REFERENCE	DESCRIPTION	PART NO.
A1	Logic Board Assy.	MA-378	G7	74LS157 Quad 2-input multiplexer	XO-114
A2	8284 CLK Driver	XO-478	G8	74LS174 Dual D-type flip flop	XO-134
A3	74LS152 Quad 2-input "NOR" gate	XO-428	G9	74LS157 Quad 2-input multiplexer	XO-124
AB, AS, AI0	74LS157 Octal "D" Flip Flop	XO-192	G10	74LS245 Octal bus transceiver	XO-79
B1	8088 CPU	XO-490	G11	74LS157 Quad 2-input flip flop	XO-96
B2	74LS373 Octal D-type flip flop	XO-445	G12	74LS157 Quad 2-input multiplexer	XO-390
B4	74LS367 Hex 3-state buffer	XO-444	G13, G14, G15	7489 64-bit RAM	XO-88
B5	74LS158 Quad 2-input "AND" gate	XO-386	G16, G17	74LS174 Hex D flip flop	XO-442
B6	74LS138 Decoder/multiplexer	XO-190	H1, H2, H3, H4	74LS189 64-bit RAM	XO-89
B7	74LS139 Dual 1 of 4 decoder	XO-419	H5, H6	74LS161 Synchronous presettable binary counter	XO-488
B8	74LS138 1 of 8 decoder	XO-113	H7, H8, H9, H10	74LS157 Quad 2-input multiplexer	XO-390
B9, B10	74LS138 1 of 8 decoder	XO-437	H11	74LS260 Dual 5-input "NOR" gate	XO-93
B11, B12, B14	74LS240 Octal Buffer/line driver	XO-61	H12	74LS268 Quad 2-port register	XO-118
C3	74LS157 Quad 2-input flip flop	XO-445	H13	74LS157 Quad 2-input multiplexer	XO-390
C4	74LS245 Octal Bus Transceiver	XO-79	H14	74LS157 Quad 2-input multiplexer	XO-427
C5	RAM # 61616P-4	XO-191	H15	74LS157 Quad 2-input multiplexer	XO-432
C6	RAM 1 61616P-4	XO-191	H16, H17	74LS158 Dual 2-input exclusive "OR" gate	XO-435
C7	RAM 2 2128-2	XO-195	J1, J2, J3	74LS189 64-bit RAM	XO-89
C11-12	ROM # 2764 8K x 8 EPROM	XO-489	J4, J5, J6	74LS189 64-bit RAM	XO-89
C12-13	ROM 1 2764 8K x 8 EPROM	XO-489	J7	74LS157 Quad 2-input multiplexer	XO-427
C13-14	ROM 2 2764 8K x 8 EPROM	XO-489	J8	74LS157 Quad 2-input multiplexer	XO-427
D1	74LS139 Dual 1 of 4 Decoder	XO-419	J9, J10, J11	74LS157 Quad 2-input multiplexer	XO-427
D2, D3, D4, D5, D6, D7, D8, D9	74LS157 Quad 2-input multiplexer	XO-114	J12, J13	74LS157 Quad 2-input multiplexer	XO-427
D10	74LS157 Quad 2-input multiplexer	XO-114	J14	74LS157 Quad 2-input multiplexer	XO-427
D11	74LS157 Quad 2-input multiplexer	XO-114	J15	74LS157 Quad 2-input multiplexer	XO-427
D12	74LS157 Quad 2-input multiplexer	XO-114	J16, J17	74LS157 Quad 2-input multiplexer	XO-427
D13	74LS157 Quad 2-input multiplexer	XO-114	K1	74LS157 Quad 2-input multiplexer	XO-427
D15	74LS157 Quad 2-input multiplexer	XO-114	K2	74LS157 Quad 2-input multiplexer	XO-427
D16	74LS157 Quad 2-input multiplexer	XO-114	K3	74LS157 Quad 2-input multiplexer	XO-427
D17	74LS157 Quad 2-input multiplexer	XO-114	K4	74LS157 Quad 2-input multiplexer	XO-427
E1-2, E2-3, E4	93417 64 x 9 bipolar RAM	XO-99	K5	74LS157 Quad 2-input multiplexer	XO-427
E5	74LS157 Quad 2-input multiplexer	XO-114	K6	74LS157 Quad 2-input multiplexer	XO-427
E6	74LS157 Quad 2-input multiplexer	XO-114	K7-8	74LS157 Quad 2-input multiplexer	XO-427
E7	4801 1K x 8 RAM	XO-193	K9, K10, K11	74LS157 Quad 2-input multiplexer	XO-427
E8, E9-10	74LS245 Octal Bus Transceiver	XO-79	K12	74LS157 Quad 2-input multiplexer	XO-427
E10-11	4801 1K x 8 RAM	XO-193	K13	74LS157 Quad 2-input multiplexer	XO-427
E11-12	2732A (BCD) 4K x 8 EPROM	XO-485	K14	74LS157 Quad 2-input multiplexer	XO-427
E13	2732A (BCD) 4K x 8 EPROM	XO-485	K15	74LS157 Quad 2-input multiplexer	XO-427
E15	74LS158 Quad 2-input exclusive "OR" gate	XO-435	K16	74LS157 Quad 2-input multiplexer	XO-427
E16	74LS273 8-bit register	XO-94	K17	74LS157 Quad 2-input multiplexer	XO-427
E17	74LS157 Quad 2-input multiplexer	XO-114	L4, L5, L6, L7	74LS157 Quad 2-input multiplexer	XO-427
F5	74LS157 Quad 2-input multiplexer	XO-114	L10	74LS157 Quad 2-input multiplexer	XO-427
F6	74LS157 Quad 2-input multiplexer	XO-114	L11	74LS157 Quad 2-input multiplexer	XO-427
F15	74LS157 Quad 2-input multiplexer	XO-114	L12	74LS157 Quad 2-input multiplexer	XO-427
F16	74LS157 Quad 2-input multiplexer	XO-114	L13	74LS157 Quad 2-input multiplexer	XO-427
F17	74LS157 Quad 2-input multiplexer	XO-114	L13-14	74LS157 Quad 2-input multiplexer	XO-427
G1, G2, G3, G4, G5	74LS157 Quad 2-input multiplexer	XO-390			
G6	74LS157 Quad 2-input multiplexer	XO-440			

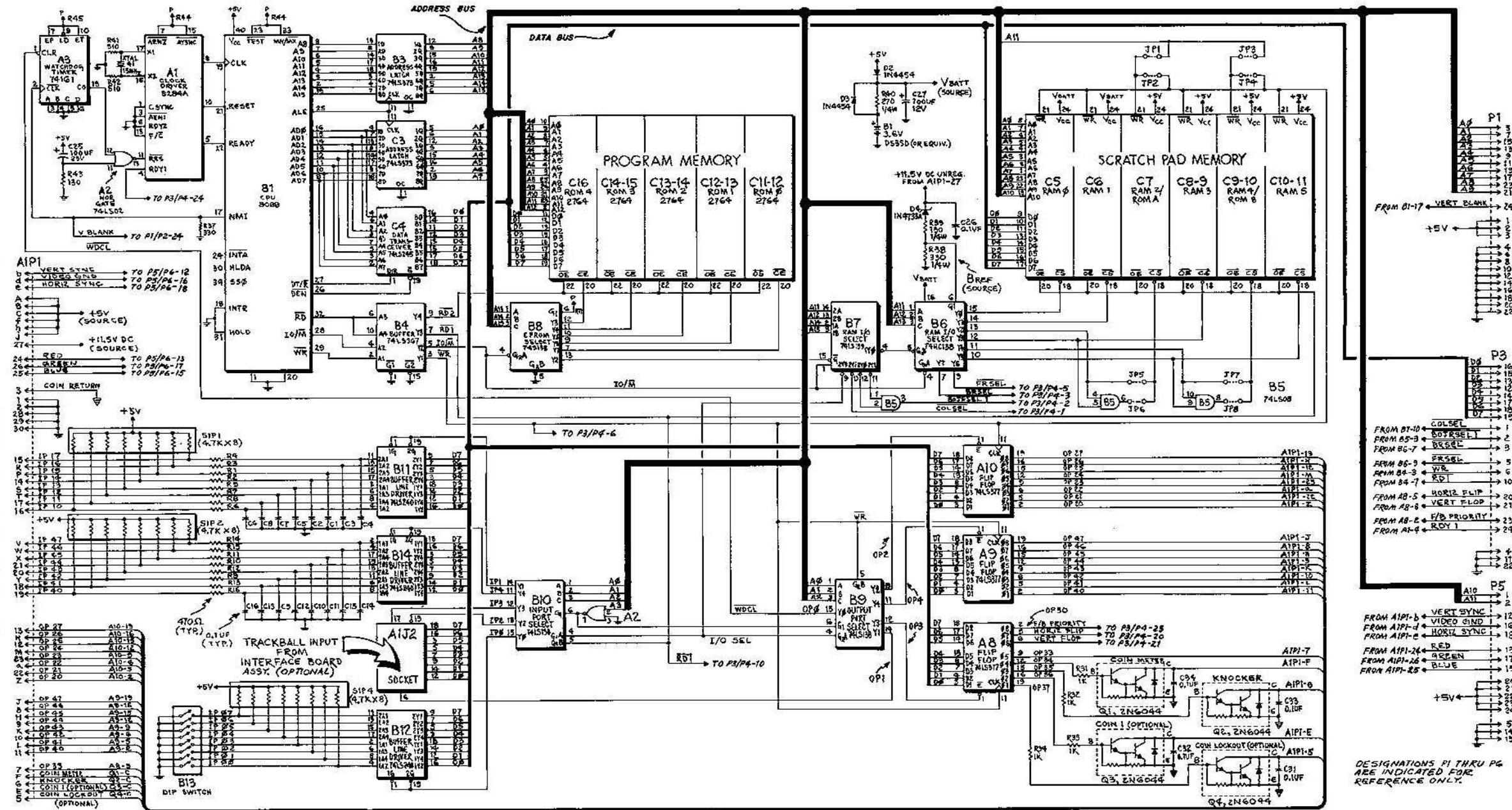

LOGIC BOARD ASSY. (A1), SCHEMATIC DIAGRAM, SHEET 1 OF 2

X. WIRING AND SCHEMATIC DIAGRAMS, PARTS LISTS

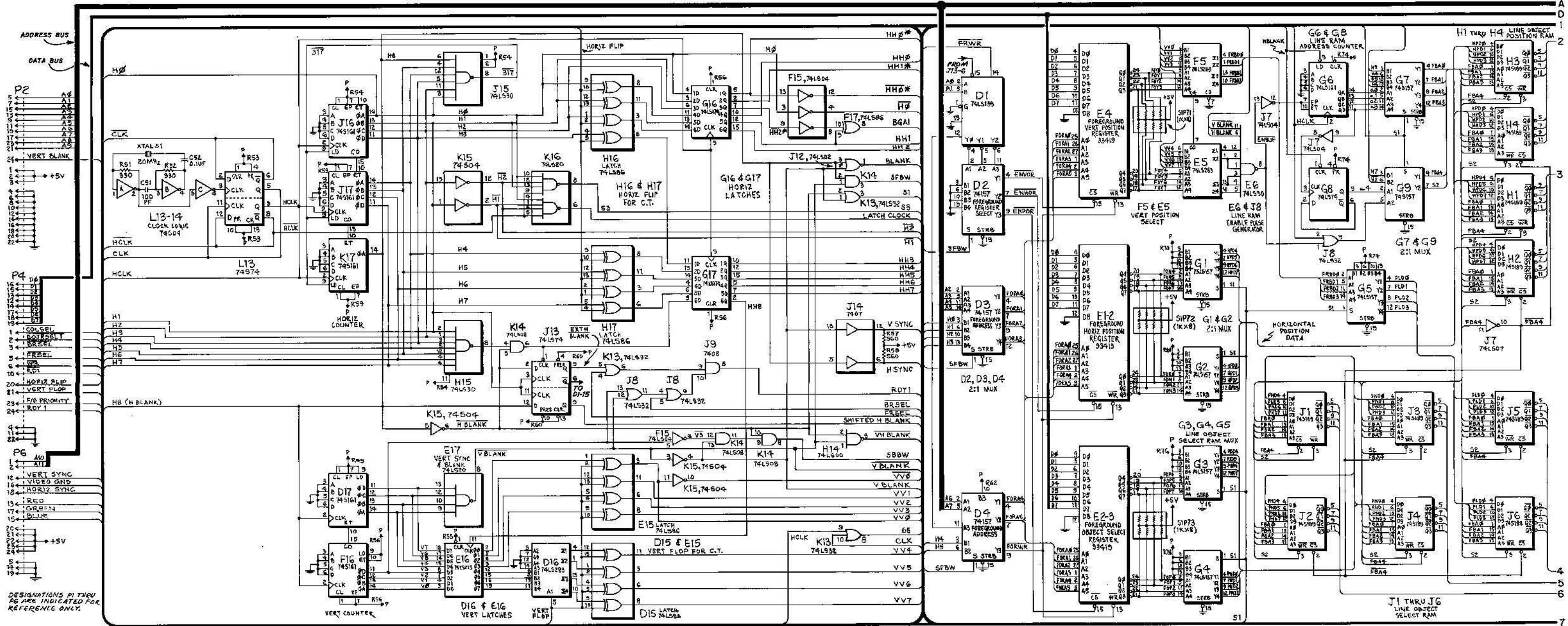

LOGIC BOARD ASSY. (A1), SCHEMATIC DIAGRAM, SHEET 2 OF 3

X. WIRING AND SCHEMATIC DIAGRAMS, PARTS LISTS

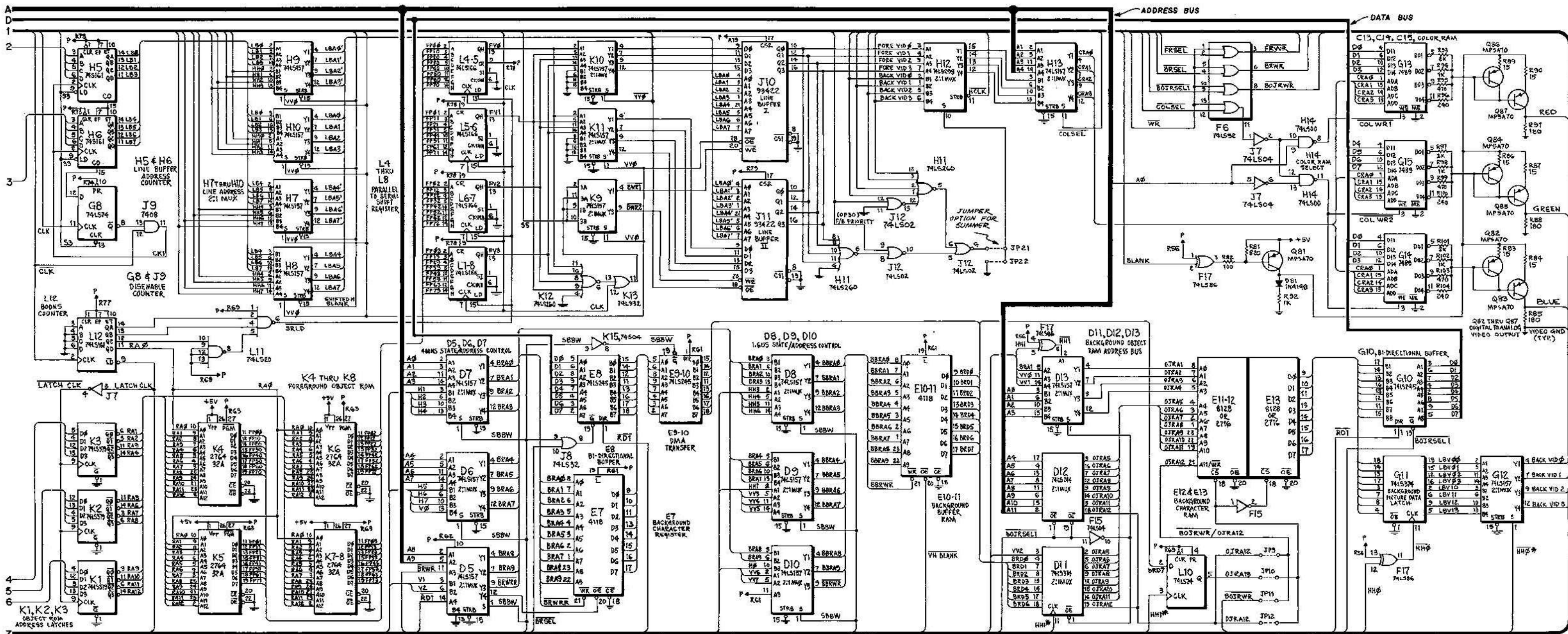

LOGIC BOARD ASSY. (A1), SCHEMATIC DIAGRAM, SHEET 3 OF 3

X. WIRING AND SCHEMATIC DIAGRAMS, PARTS LISTS

POWER SUPPLY ASSY. (A3), COMPONENT LOCATION

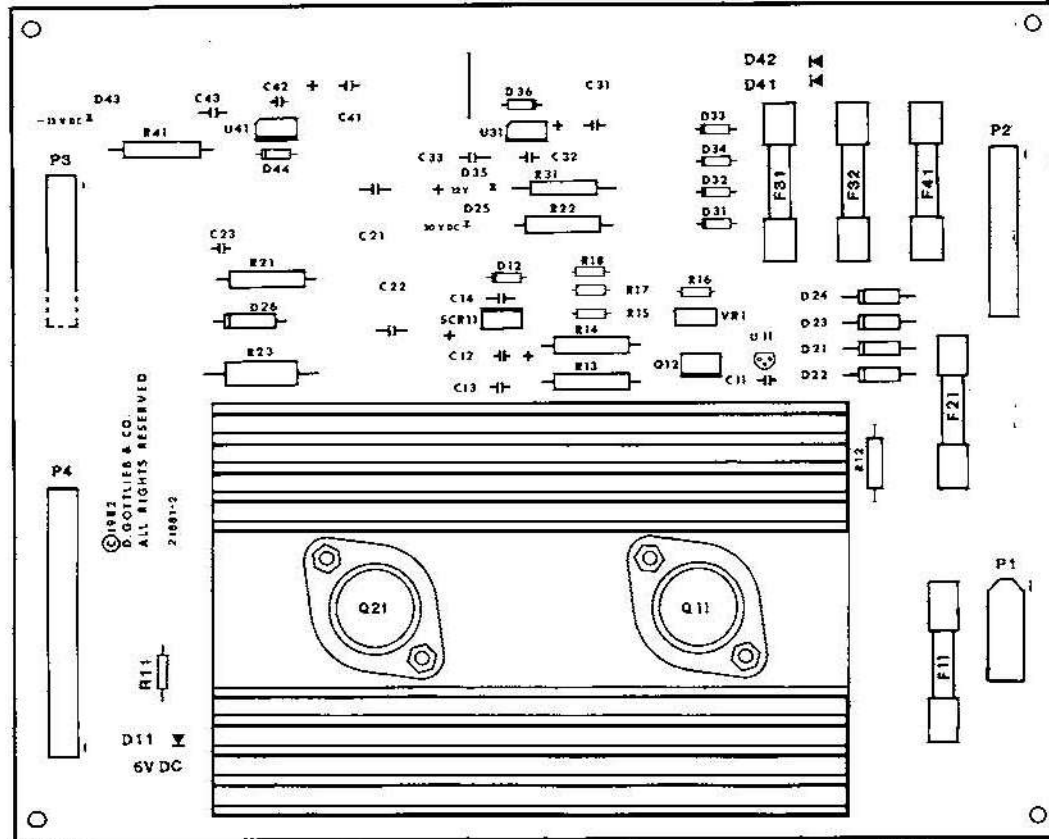

POWER SUPPLY ASSY. (A3), PARTS LIST

REFERENCE	DESCRIPTION	PART NO.	REFERENCE	DESCRIPTION	PART NO.
C11, C32, C42	Power Supply Assy.	MA-430	P2	Connector, 10 PIN	XO-531
C12	Capacitor, .01 mfd., 50V	XO-229	P3	Connector, 7 PIN	XO-526
C13, C23	Capacitor, 100UF, 16V	XO-235	P4	Connector, 16 PIN	XO-372
C14, C33, C43	Capacitor, 0.1UF, 100V	XO-234	Q11	Transistor, PNP, 2N5879	XO-323
C21, C22	Capacitor, 0.2UF, 16V	XO-205	Q12	Transistor, NPN, TIP31B	XO-641
C31, C41	Capacitor, 2200UF, 75V	XO-132	Q21	Transistor, NPN, 2N3055	XO-301
D11, D25	Capacitor, 470UF, 35V	XO-284	R11	Resistor, 470 OHM, 5% 1/4W	XO-55
D35, D43	Diode, Light Emitting MV-5752	XO-270	R12	Resistor, 100 OHM, 5% 1/4W	XO-137
D12	Diode, Zener, 5.6V, 5% 1W, IN4734A	XO-255	R13, R14	Resistor, 12 OHM, 5% 2W	XO-138
D21-D24	Diode, IN5401	XO-263	R15	Resistor, 200 OHM, 5% 1/4W	XO-143
D26	Diode, Zener, 30V, 5% 5W, IN5363B	XO-273	R16	Resistor, 180 OHM, 5% 1/4W	XO-24
D31-D34, D36	Diode, IN4004	XO-254	R17	Resistor, 100 OHM, 5% 1/4W	XO-28
F11, D41, D42, D44	Fuse, 6A AMP SLO-BLO	EL-8	R18	Resistor, 20 OHM, 5% 1/4W	XO-29
F21	Fuse, 2 AMP SLO-BLO	EL-7	R21, R22	Resistor, 1.8K OHM, 5% 2W	XO-135
F31, F32	Fuse, 1/4 AMP SLO-BLO	EL-5	R23	Resistor, 200 OHM, 5% 5W	XO-133
F41	Fuse, 1 AMP SLO-BLO	EL-6	R31, R41	Resistor, 750 OHM, 5% 1W	XO-136
P1	Connector, 4 PIN	PS-67	SCR11	Silicon Controlled Rectifier	XO-131
			U11	Diode, Programmable Zener TL431	XO-272
			U31	Voltage Regulator -12V, LM 340T	XO-473
			L31	Voltage Regulator -12V, LM 320	XO-130
			VR1	Potentiometer, 100 OHM	XO-134

X. WIRING AND SCHEMATIC DIAGRAMS, PARTS LISTS

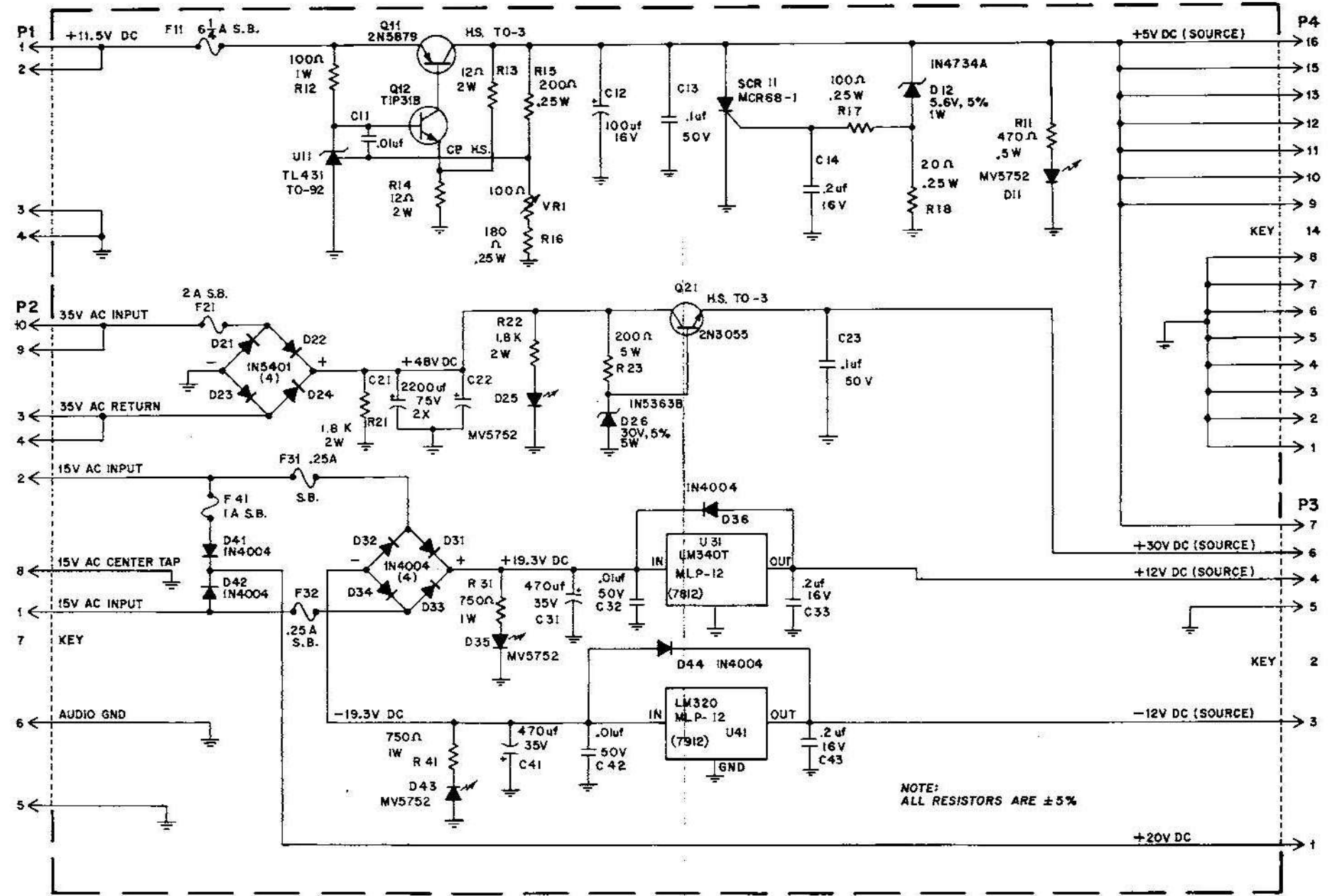

POWER SUPPLY ASSY. (A3), SCHEMATIC DIAGRAM

X. WIRING AND SCHEMATIC DIAGRAMS, PARTS LISTS

SOUND BOARD ASSY. (A6), COMPONENT LOCATION

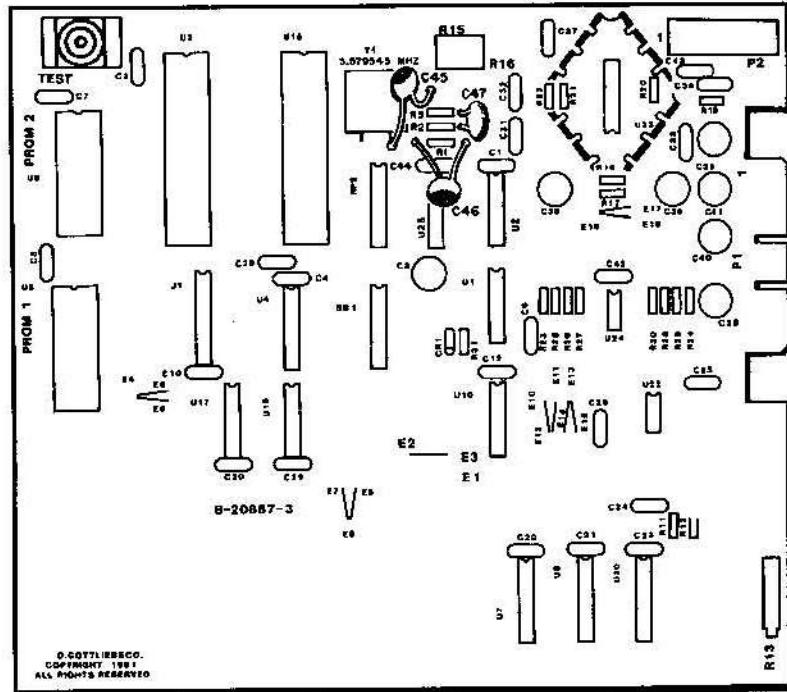

SOUND BOARD ASSY. (A6), PARTS LIST

REFERENCE	DESCRIPTION	PART NUMBER
C1, C2	Sound Board Assembly	XO-245
C4-C7, C10	Capacitor, 0.1UF, 25V	XO-245
C12, C20, C21	Capacitor, 4.7UF, 35V	XO-222
C13, C25, C26	Capacitor, 100PF	XO-273
C28, C29, C30	Capacitor, 470UF, 35V	XO-284
C33, C42, C44	Capacitor, 33PF	XO-277
C31, C32	Capacitor, 0.1UF, 100V	XO-228
C27	Capacitor, 0.047UF, 25V	XO-222
C3	Capacitor, 4.7UF, 50V	XO-210
C24	Capacitor, 100PF	XO-273
C38	Capacitor, 470UF, 35V	XO-284
C45, C48	Capacitor, 33PF	XO-277
C47	Capacitor, 0.1UF, 100V	XO-228
C81	Diode, 1N4148	XO-281
R1, R11, R12	Resistor, 5.6K ohm, 5%, 1/4W	XO-19
R2, R3	Resistor, 25 ohm, 5%, 1/4W	XO-14
R13	Potentiometer, 10K ohm	XO-108
R23-R30	Resistor, 10K ohm, 5%, 1/4W	XO-18
R18	Potentiometer, 10K ohm	XO-108
R18, R21	Resistor, 100K ohm, 5%, 1/4W	XO-35
R22	Resistor, 2K ohm, 5%, 1/4W	XO-14
R31	Resistor, 60K ohm, 5%, 1/4W	XO-189
R29	Resistor, DIP	XO-189
HD1	Switch, DIP	XO-505
SW1	Switch, Momentary Pushbutton	XO-513
U1	IC, 7414	XO-397
U2	IC, SN74LS74N	XO-434
U3	CPU, 80502-13	XO-280
U4	IC, SN74ALS24M	XO-437
U5, U6	PROM, 2716	PR-53
U7	IC, SN74LS75	XO-394
U10	IC, SN74LS02N	XO-428
U15	IC, SN74ALS16	XO-391
U16	IC, SN74ALS04N	XO-418
U17	IC, SN74ALS30N	XO-432
U20	Converter, D/A, 1408A-0P	XO-410
U22	IC, LM741P	XO-393
U23	IC, LM379	XO-395
U24	IC, Dual Comparator, LM193	XO-396
U25	Inverter, 7404	XO-402
Y1	Crystal, 3.579545MHZ	XO-436
J1	Socket, 24 Pin DIP	XO-487
J2	Socket, 24 Pin (2)	XO-529
J3	Socket, 40 Pin (2)	XO-530

X. WIRING AND SCHEMATIC DIAGRAMS, PARTS LISTS

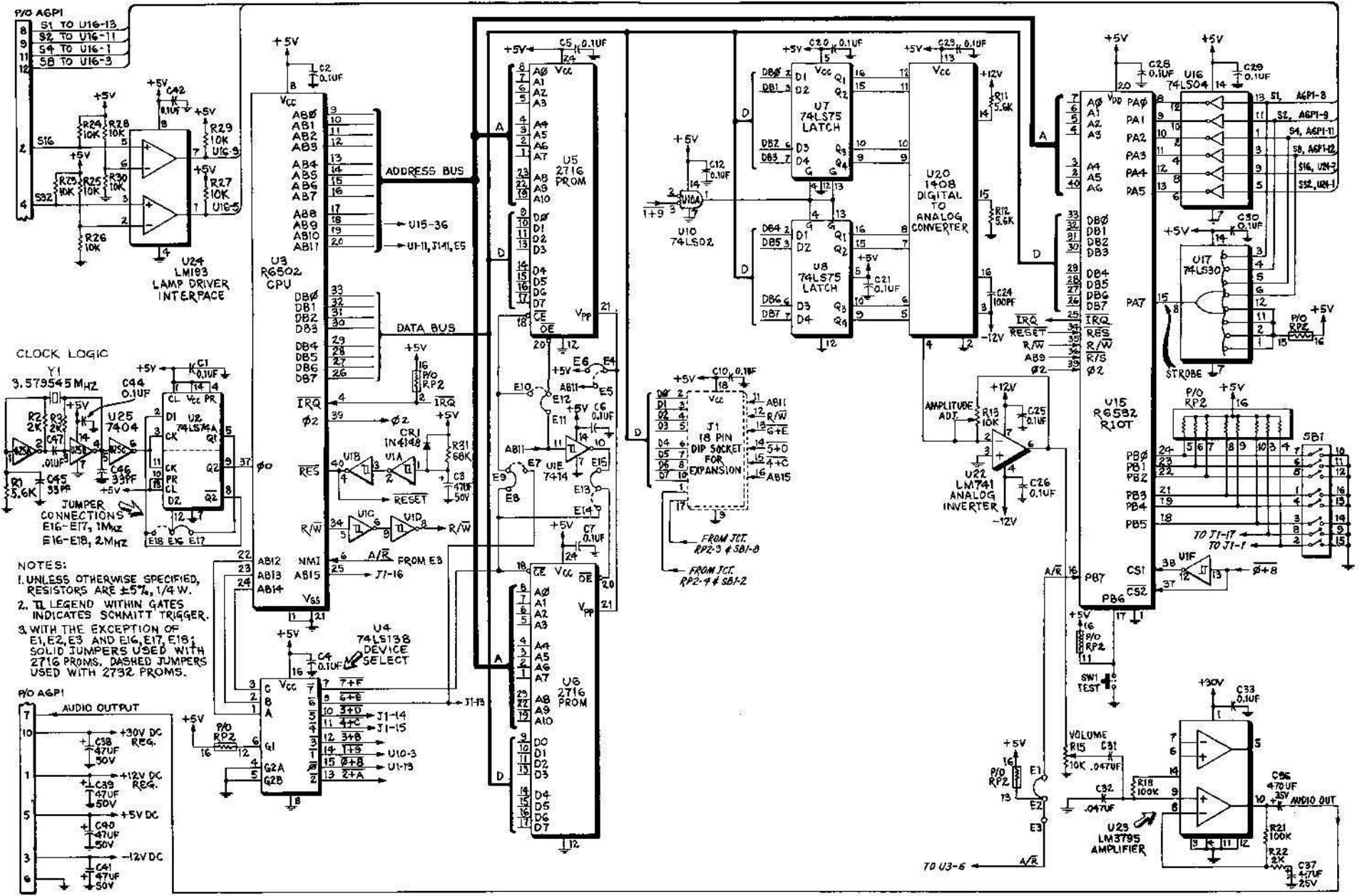

SOUND BOARD ASSY. (A6), SCHEMATIC DIAGRAM

X. WIRING AND SCHEMATIC DIAGRAMS, PARTS LISTS

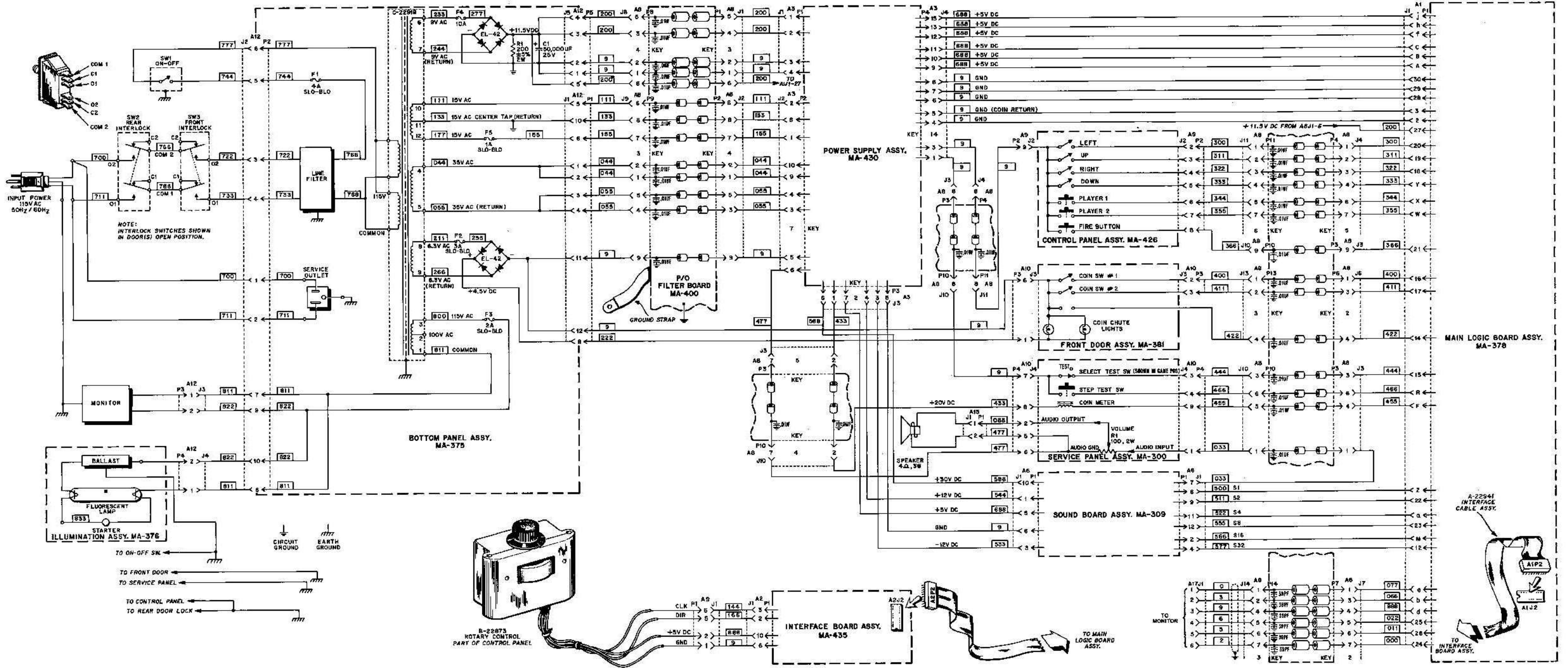

19" COLOR MONITOR SCHEMATIC DIAGRAM

MODELS 19K4901, 19K4906, 19K4951, 19K4956

Power Supply Voltage and Symbols

Symbol	Voltage	Operating Circuit
	15V	Vert. Osc. Sync Blanking CRT Cut-Off
	130V	Horiz. Osc. Horz. Drive Horz. Output Vert. Output
	175V	Video Output



SERVICE TECHNICIAN WARNING X-RAY RADIATION PRECAUTION:

THIS PRODUCT CONTAINS CRITICAL ELECTRICAL AND MECHANICAL PARTS ESSENTIAL FOR X-RAY RADIATION PROTECTION. FOR REPLACEMENT PURPOSES, USE ONLY TYPE PARTS SHOWN IN THE PARTS LIST.



CAUTION: FOR CONTINUED SAFETY, REPLACE SAFETY CRITICAL COMPONENTS ONLY WITH MANUFACTURER'S RECOMMENDED PARTS.
AVERTISSEMENT: POUR MAINTENIR LE DEGRE DE SECURITE DE L'APPAREIL NE REMPLACER LES COMPOSANTS DON'T LE FONCTIONNEMENT EST CRITIQUE POUR LA SECURITE QUE PAR DES PIECES RECOMMANDEES PAR LE FABRICANT.

OSCILLOSCOPE WAVEFORM PATTERN

The waveforms shown are as observed on the wide band oscilloscope with the monitor turned to a reasonably strong signal and a normal picture. The voltages shown on each waveform are the approximate peak amplitudes.

If the waveforms are observed on the oscilloscope with a poor high frequency response, the corner of the pulses will tend to be more rounded than those shown and the amplitude of any high frequency pulse will tend to be less.

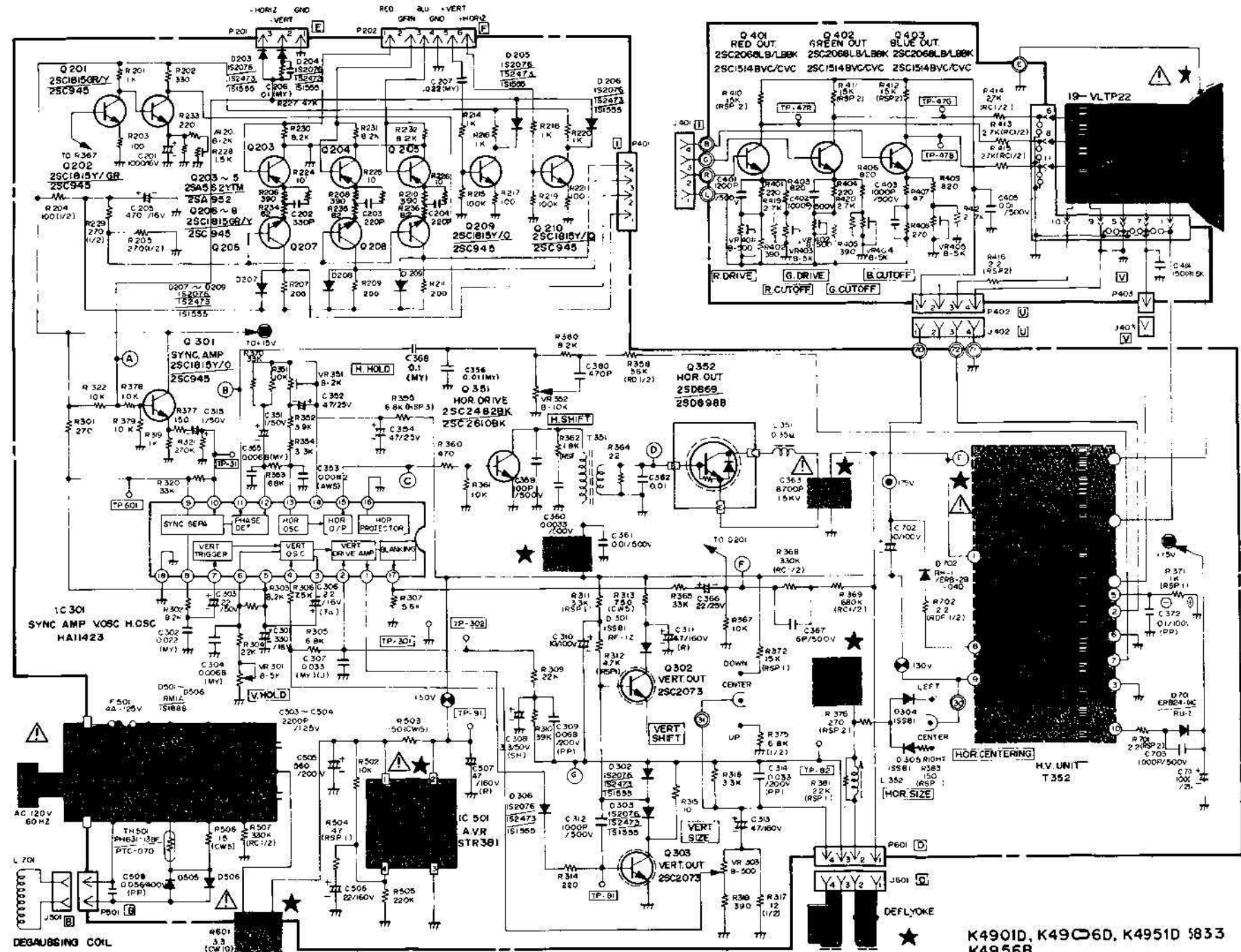
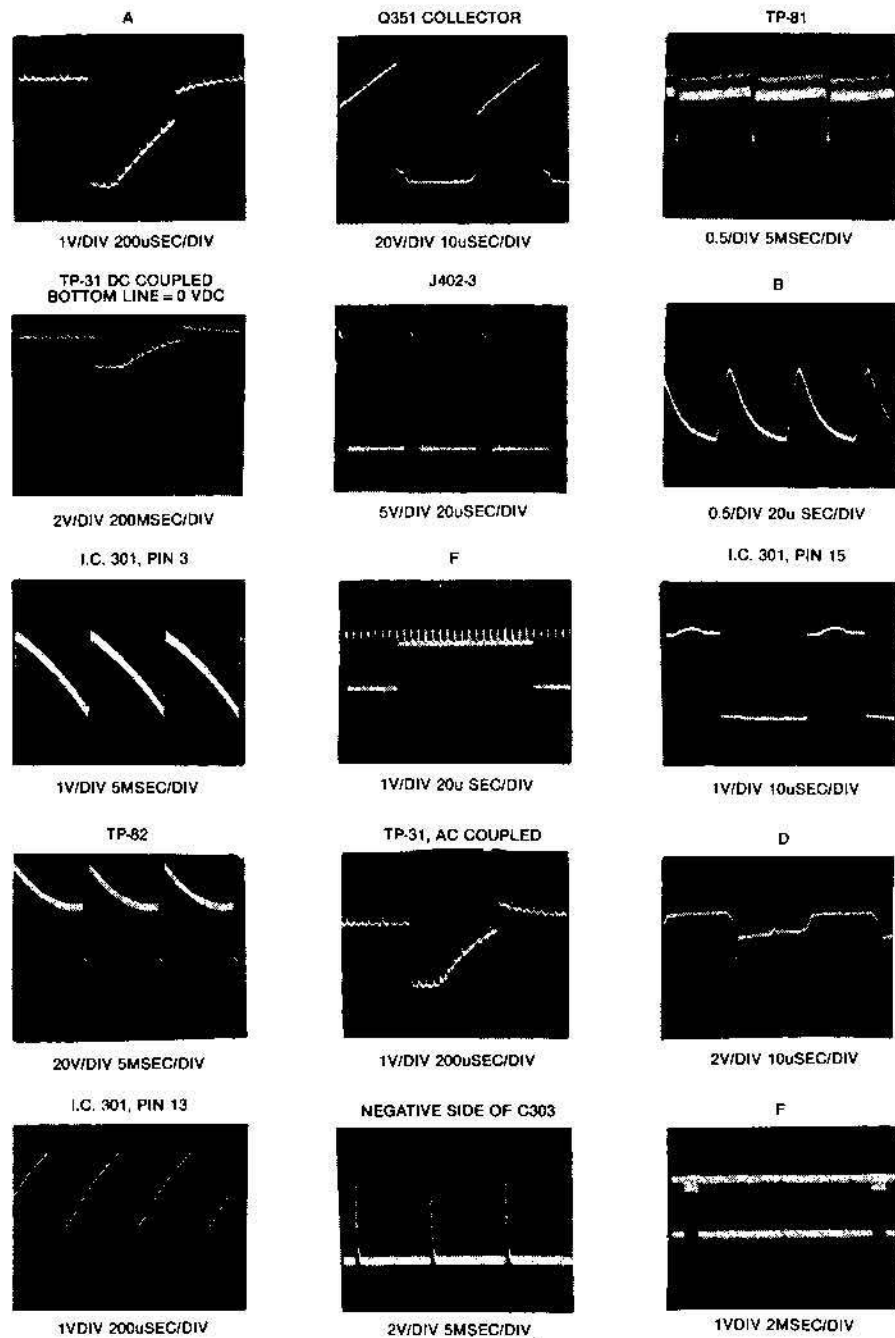

K4901D, K4906D, K4951D 5833
K4956B

X. WIRING AND SCHEMATIC DIAGRAMS, PARTS LISTS

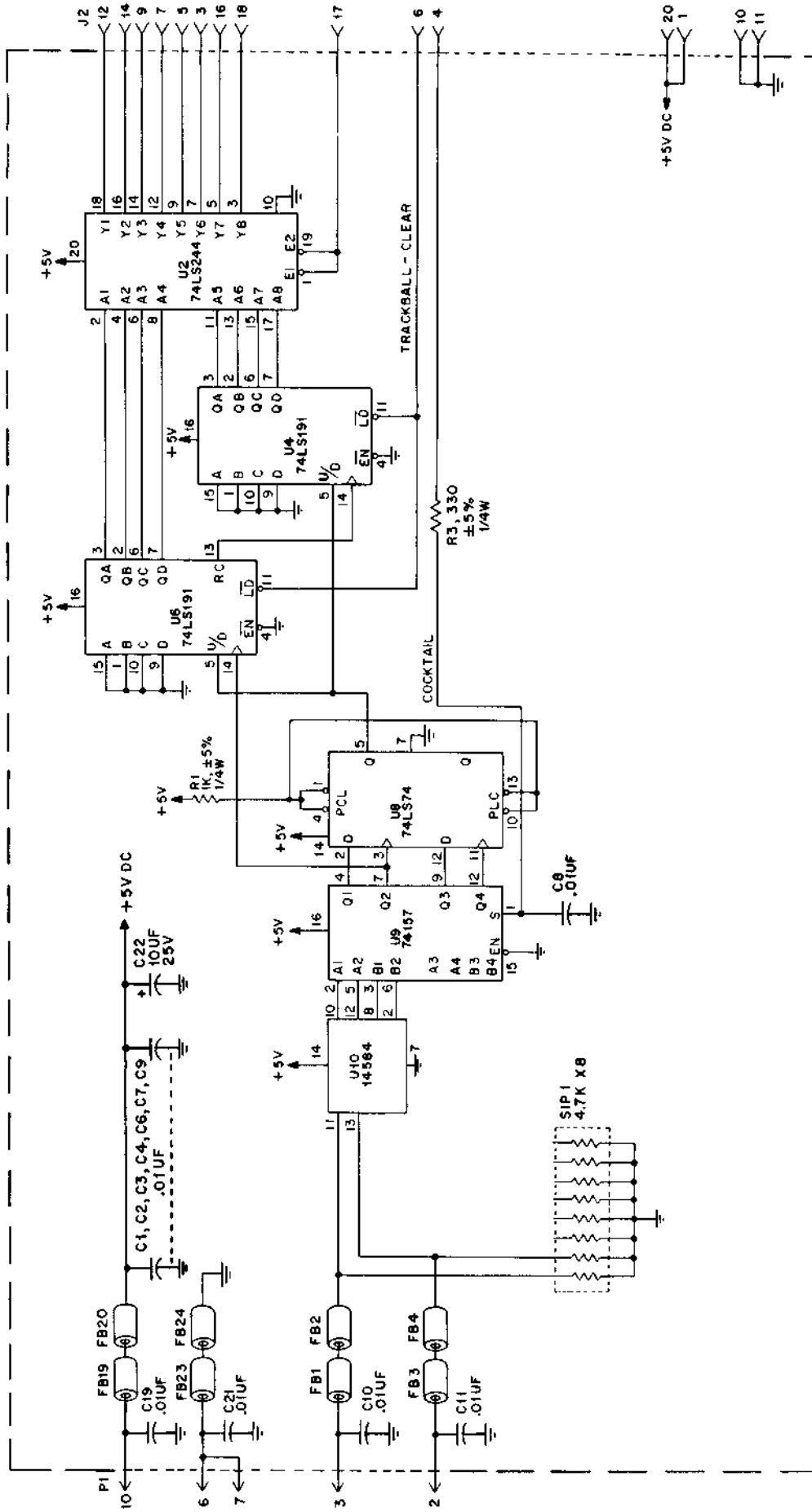

INTERFACE ASSY. (A2), SCHEMATIC DIAGRAM

X. WIRING AND SCHEMATIC DIAGRAMS, PARTS LISTS

INTERFACE ASSY. (A2), COMPONENT LOCATION

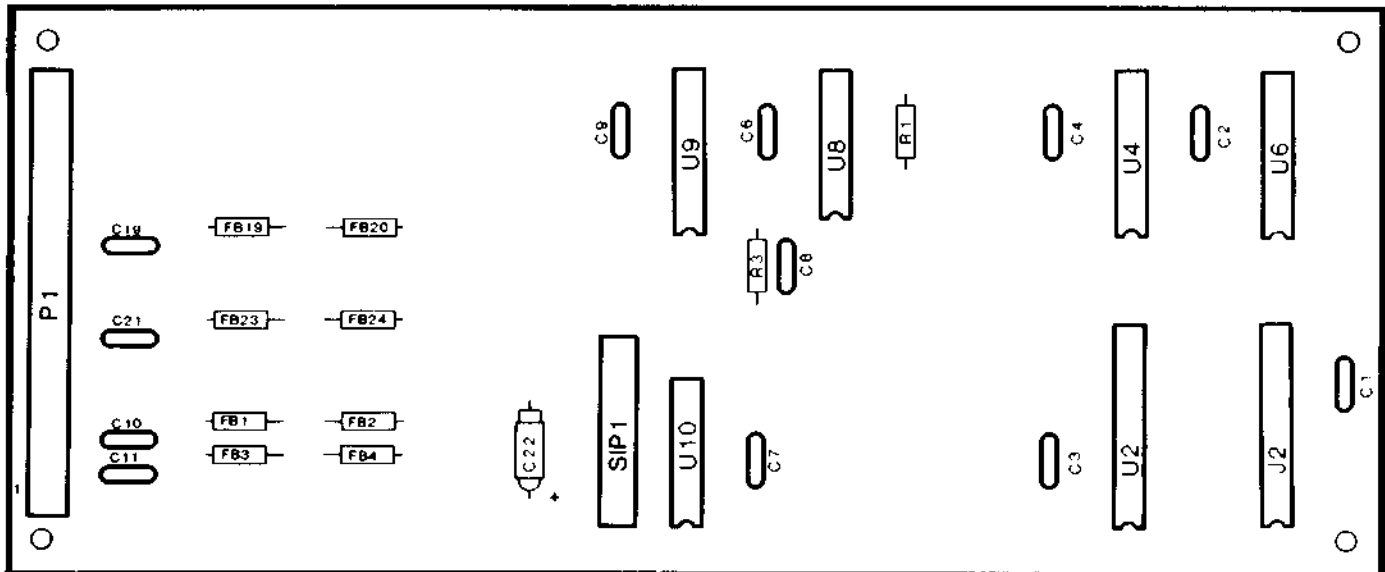

INTERFACE ASSY. (A2), PARTS LIST

ITEM	DESCRIPTION	PART NO.
	Interface Board Assy.	MA-435
C1-C4	Capacitor, .01UF, 50V, AX, CM.	XO-229
C6-C11		
C19, C21		
C22	Capacitor, 10UF, 25V, AX, TANT	XO-127
R1	Resistor, 1K OHM, 5%, 1/4W	XO-5
R3	Resistor, 330 OHM, 5%, 1/4W	XO-34
SIP 1	Resistor, DIP, 4.7K, 9 Pin	XO-492
FB1-FB4	Ferrite Bead	XO-338
FB19, FB20		
FB23, FB24		
J2	Socket, DIP, 20 Pin	XO-491
U2	IC, 74LS244, Octal Buffer	XO-117
U4, U6	IC, 74LS191, Binary Counter	XO-116
U8	IC, 74LS74, Dual Flip-Flop	XO-434
U9	IC, 74157, 2-1 Multiplexer	XO-114
U10	IC, 14584, CMOS Inverter	XO-119
P1	Plug, 14 Pin	XO-145

LIMITED WARRANTY

D. Gottlieb & Co. warrants to the initial purchaser of the D. Gottlieb & Co. machine that the items listed in the following schedule as installed and used in the original D. Gottlieb & Co. machine will for the applicable period set forth in the schedule, computed from the initial date of purchase from an authorized D. Gottlieb & Co. distributor, be free of defects in materials and workmanship:

SCHEDULE

<u>GAME</u>	<u>ITEM</u>	<u>WARRANTY PERIOD</u>
Pinball	All Electronic Printed circuit boards	90 days
Pinball-Video	All Electronic Printed Circuit Boards	90 days
	Card Cage	90 days
	Television Monitor	30 days
Video	All Electronic Printed Circuit Boards	90 days
	Television Monitor	30 days

This Limited Warranty does not apply to any parts damaged in the course of handling or assembling by the customer or damage due to other than normal use or use in violation of instructions or reasonable practices, or further damaged in return shipment. This Limited Warranty is made only to the original customer, and is and shall be in lieu of all other warranties expressed or implied, and of all other obligations or liabilities on the part of D. Gottlieb & Co. and in no event shall D. Gottlieb & Co. be liable for any anticipated profits, consequential damages, loss of time, or other losses incurred by the customer in connection with the purchase or operation of D. Gottlieb & Co. machines or components thereof.

The registration card with each D. Gottlieb & Co. factory-wired machine must be filled in and returned to D. Gottlieb & Co. within ten days after date of purchase for this Limited Warranty to be effective. This Limited Warranty applies only to machines so registered.

THIS LIMITED WARRANTY IS IN LIEU OF ANY OTHER EXPRESS OR IMPLIED WARRANTIES, INCLUDING ANY IMPLIED WARRANTY OF MERCHANTABILITY OR FITNESS, AND OF ANY OTHER OBLIGATION ON THE PART OF THE SELLER AND D. GOTTLIEB & CO.

The logo for Gottlieb Amusement Games features a stylized starburst graphic to the left of the word "Gottlieb" in a bold, sans-serif font. Below "Gottlieb" is the phrase "AMUSEMENT GAMES" in a smaller, all-caps, sans-serif font.

Gottlieb
AMUSEMENT GAMES



Gottlieb
AMUSEMENT GAMES

165 W. Lake Street Northlake, IL 60164
(312) 362-7400 Telex 72-8463

A Columbia Pictures Industries Company