



BAGMAN

INSTALLATION

&

OPERATION



126-10-200-M

STERN *ELECTRONICS, INC.*
700 Chase Avenue
Elk Grove Village, IL 60007
312/981-9600

TOLL FREE SERVICE (800) 621-6424 ILL. ONLY (800) 572-1948

- . The objective of the game is to maneuver the Bagman thru the various mine shafts picking up the various money bags and placing the money bags in the wheelbarrow which is at the surface of the mine.
- . The money bag bonus is time operated. When a money bag is picked up and placed in the wheelbarrow, whatever bonus is showing at that time is awarded. The bonus then reverts back to its original money bag value and decrements with time. If no money bags are put in the wheelbarrow and the bonus has decremented to zero, the player(s) forfeits a life.
- . While climbing thru the mine shafts, the Bagman must avoid the pursuing guards, the moving ore carts and the descending elevator.
- . The guards may be temporarily stunned by striking them with a pickaxe or by dropping a money bag on them when they are on the same ladder as the Bagman.
- . The Bagman may move horizontally at the surface, in the shafts and via the ore cart from rack to rack with or without the wheelbarrow.
- . The Bagman is moved horizontally and vertically by the 4-way joystick. The joystick is also used to jump out of the ore cart.
- . The Action Button is used to make the Bagman perform the following tasks:
 1. Pick up and drop the money bags.
 2. Pick up and drop the pickaxe.
 3. Grab and release the ceiling beam to avoid the ore cart. This can be done while carrying a money bag.
NOTE: The Bagman when releasing from the ceiling beam ~~may~~ drop down to the mine shaft or into the ore cart. This can be done while carrying a money bag.
 4. Placing a money bag in the wheelbarrow.
 5. Pick up and drop the wheelbarrow.
- . Scoring: Points are scored for each horizontal step the Bagman takes, for each money bag placed in the wheelbarrow, and for each guard stunned.

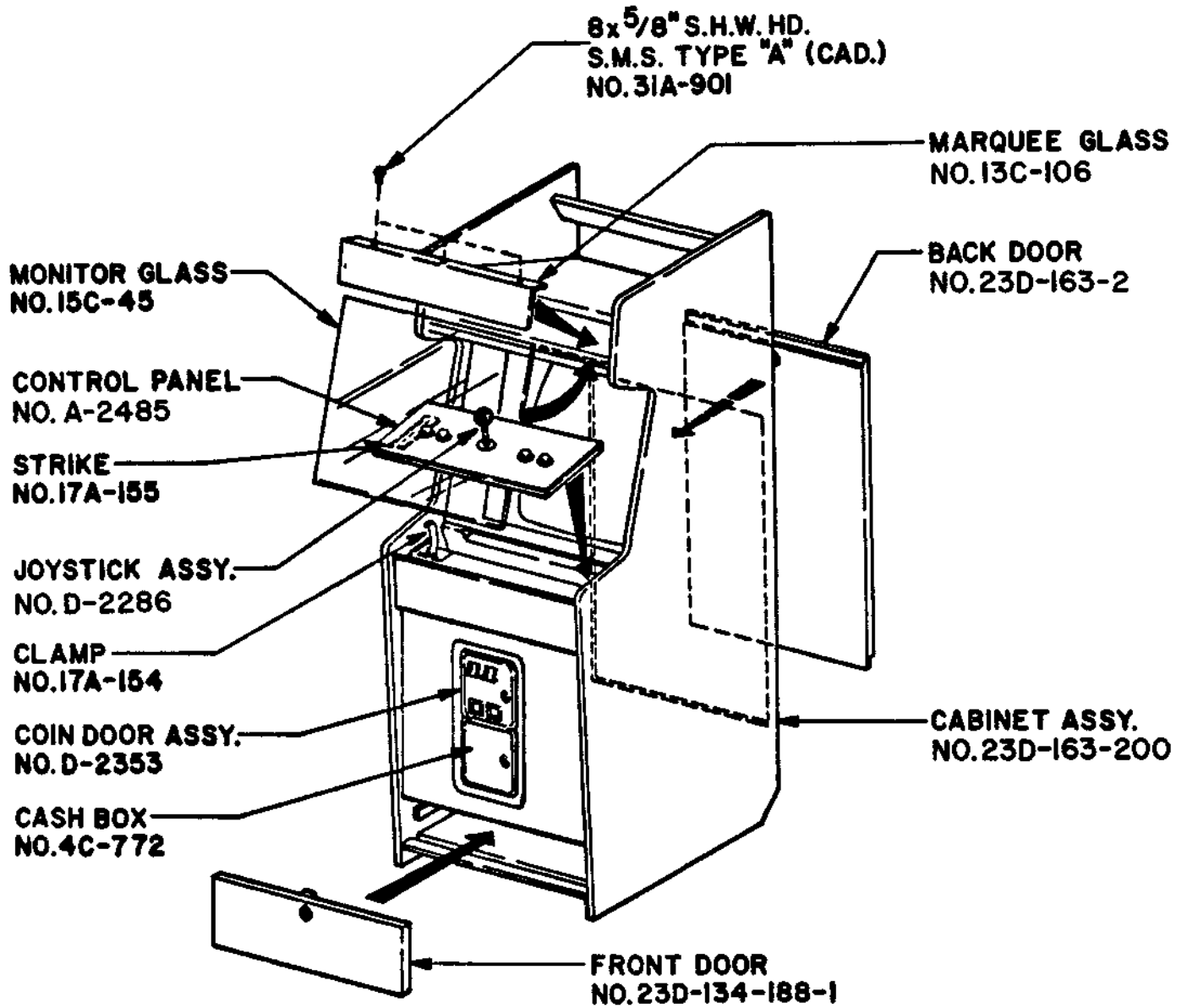

"BAGMAN" CABINET AND ASSOCIATED COMPONENTS

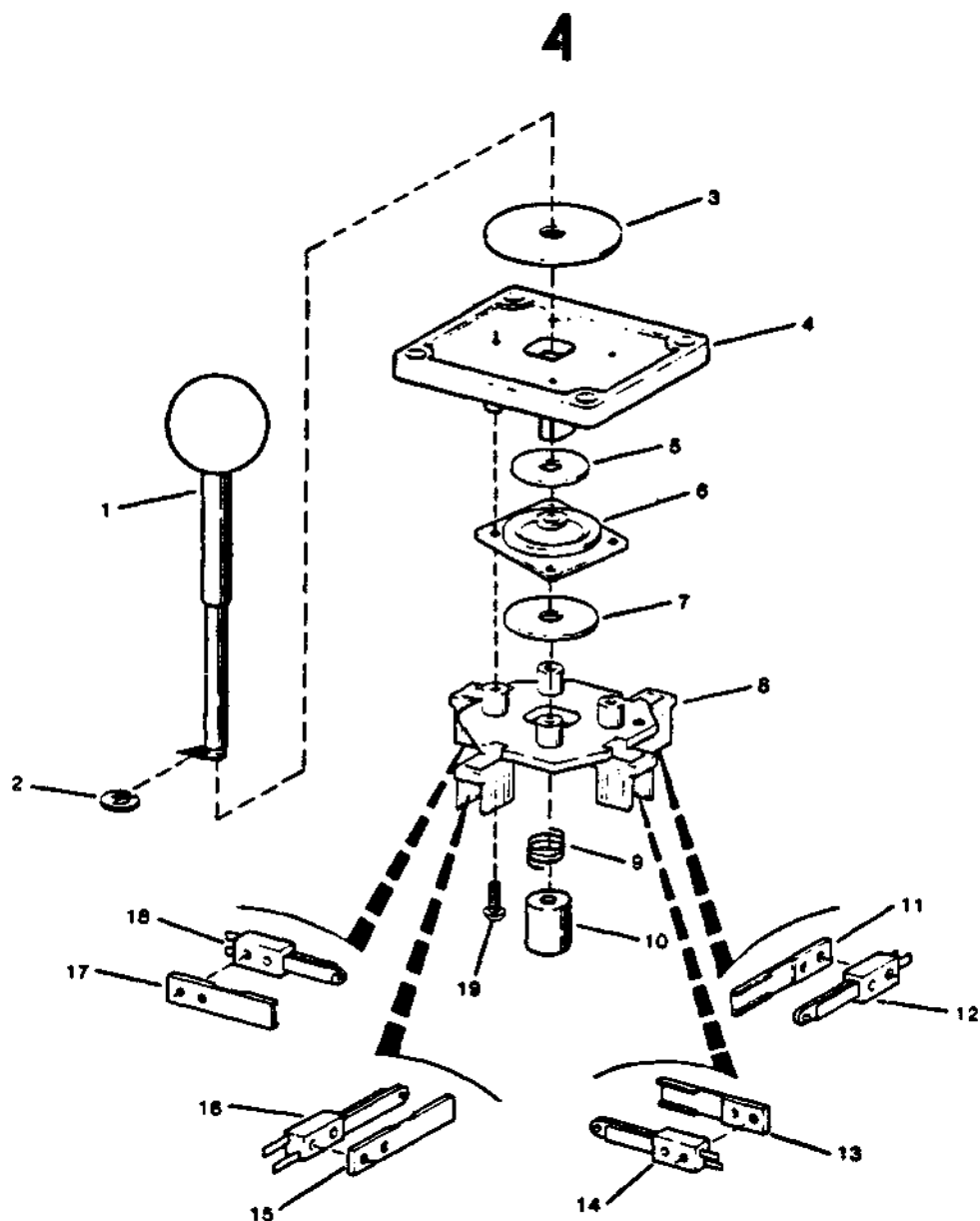

JOY STICK ASSEMBLY C-2286 (4-WAY)

**ADDENDUM 23
PARTS LIST FOR
JOY STICK ASSEMBLY C-2286
SECTION 1**

STERN PART NO.	DESCRIPTION	REFERENCE/ DESIGNATION
4A-457	Top Button	1
17A-104-37	Retaining Ring	2
3A-214	Washer	3
4A-458	Top Plate	4
3A-215	Washer	5
4A-456	Diaphragm	6
3A-216	Washer	7
4A-459	Switch Mounting Plate	8
5A-190	Spring	9
4A-460	Switch Actuator	10
4A-449	Plastic Guard Actuator	11, 13, 15, 17
8A-325-1	Moulded Switch	12, 14, 16, 18
31A-844	#6 x 1 Phil. R.H. SEMS	19

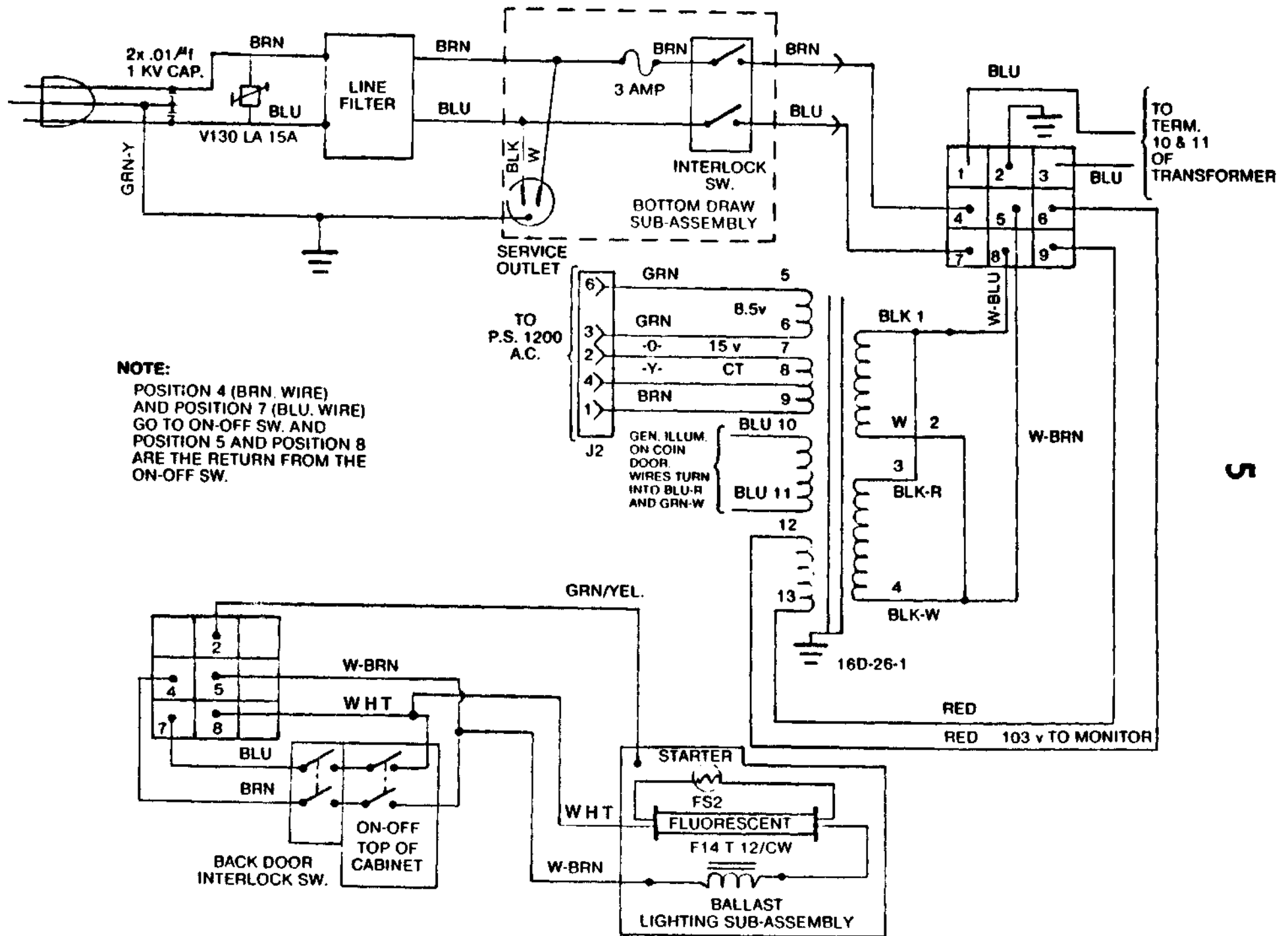

NOTE:
 POSITION 4 (BRN. WIRE)
 AND POSITION 7 (BLU. WIRE)
 GO TO ON-OFF SW. AND
 POSITION 5 AND POSITION 8
 ARE THE RETURN FROM THE
 ON-OFF SW.

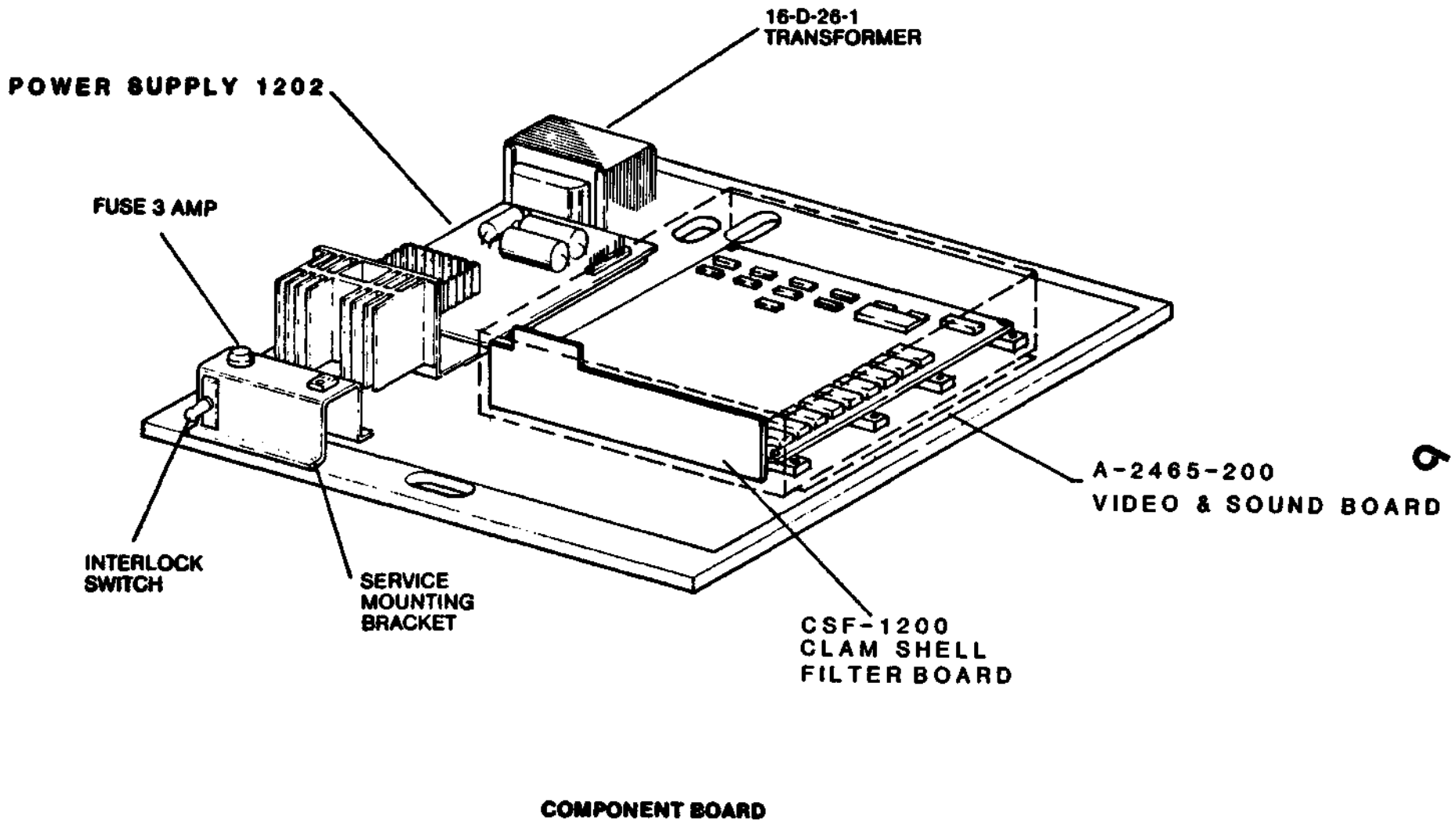

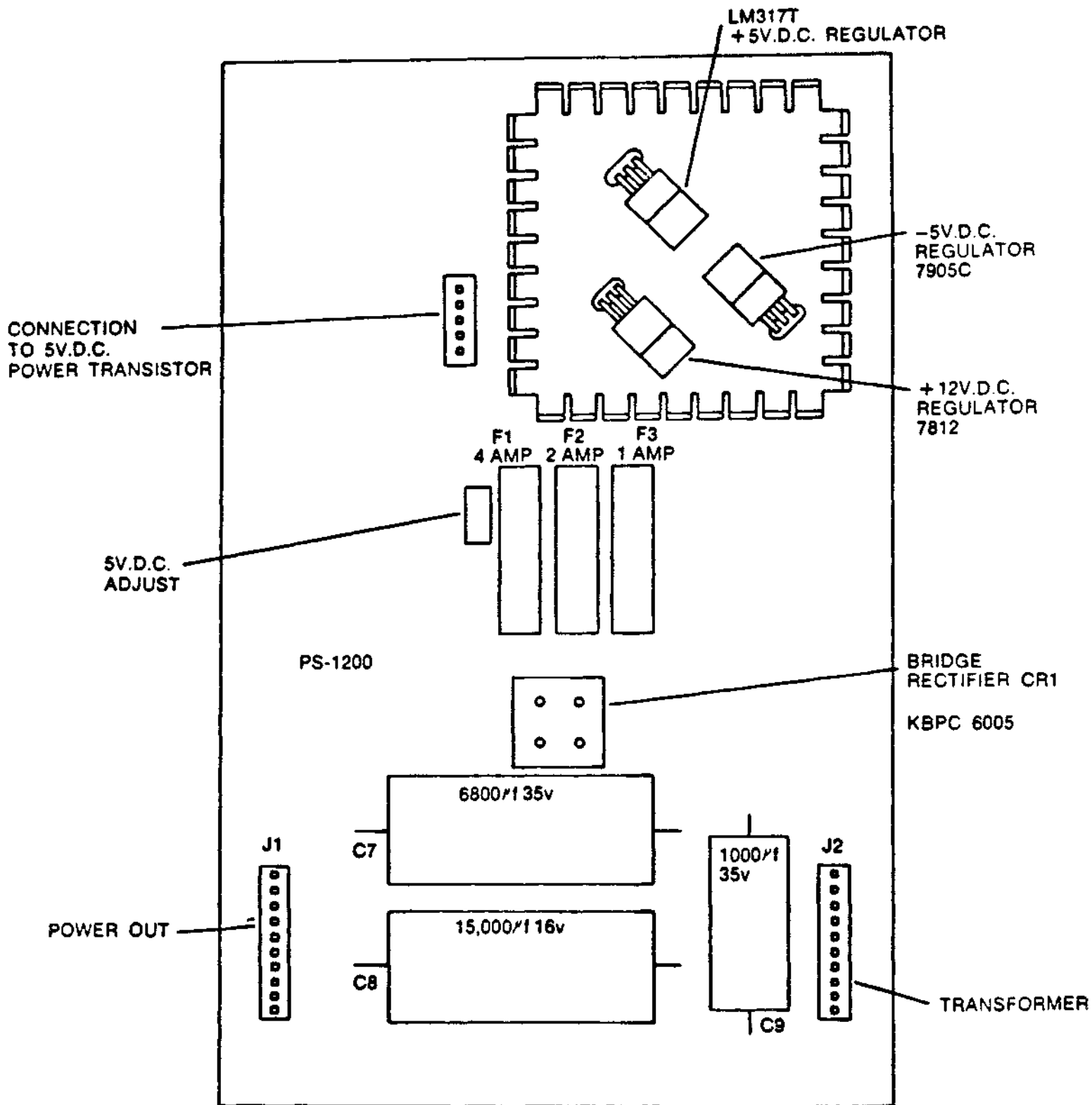
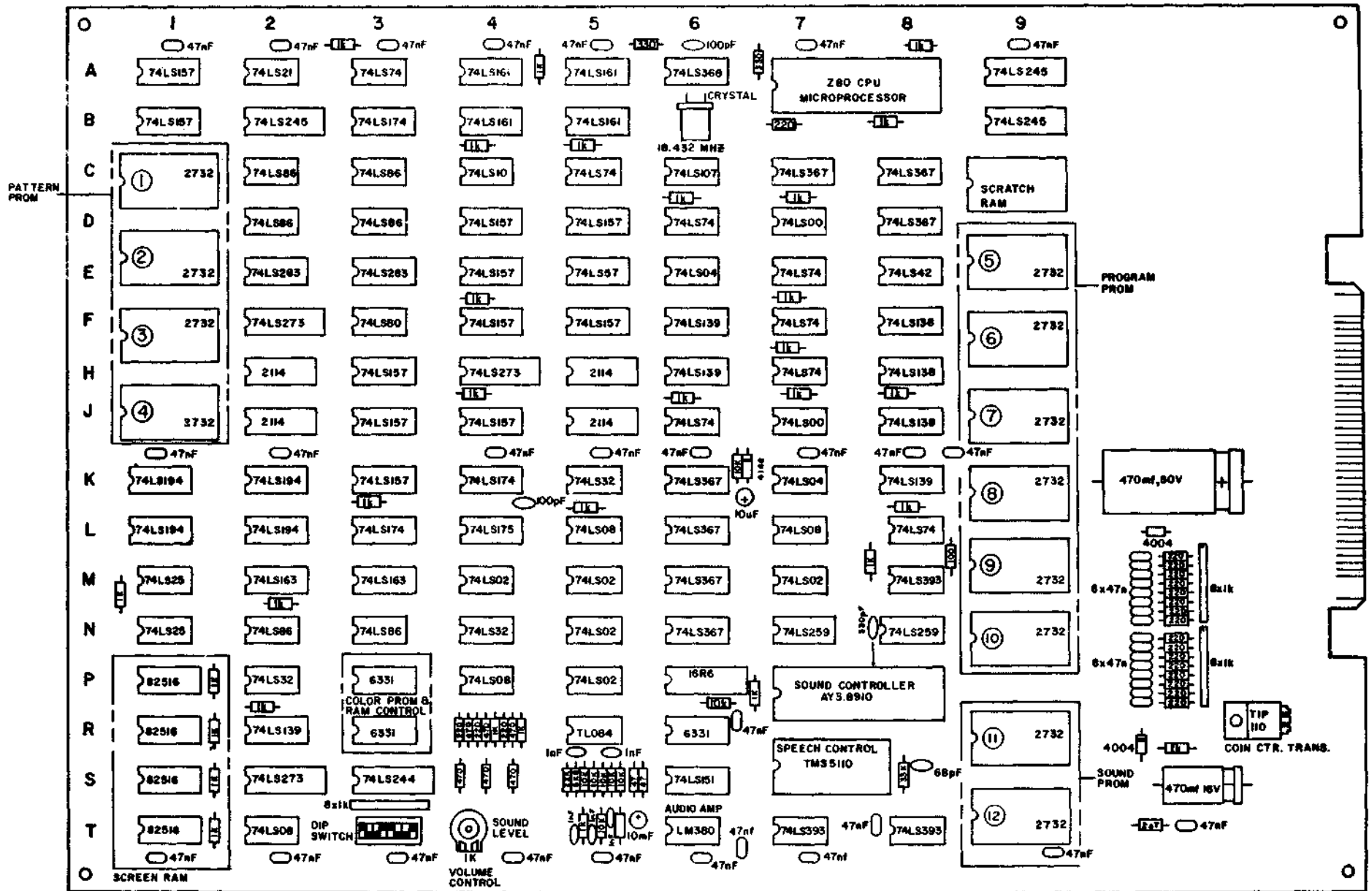
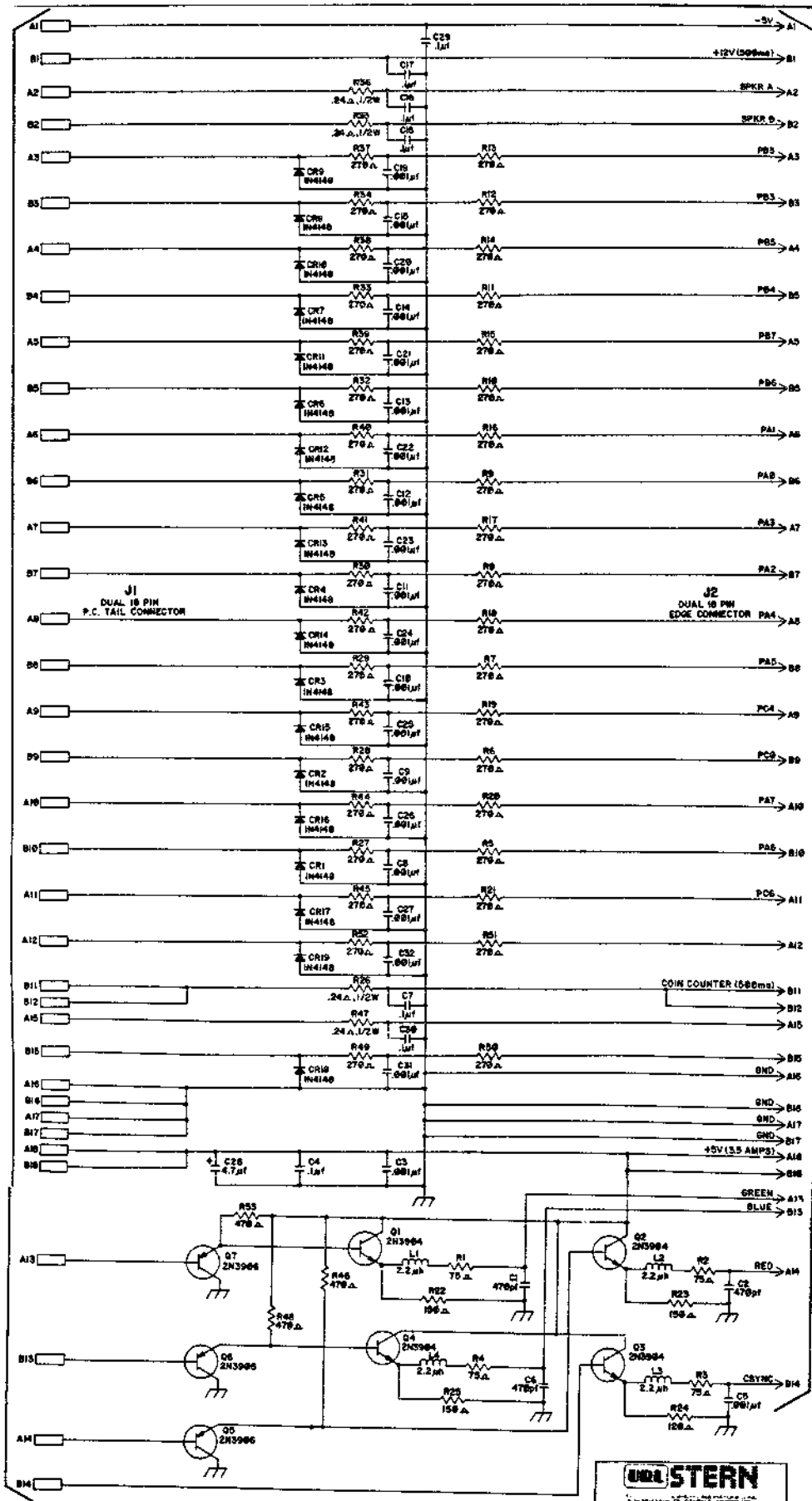

FIGURE 4. POWER SUPPLY BOARD PS-1200



VIDEO and SOUND BOARD



INDUSTERN
 SCHEMATIC, CLAM SHELL
 FILTER PC BOARD
 D 340-2101-3
 SHEET 1 OF 1

SYM	DESCRIPTION	REV	DATE
A	ISSUED E.I. #2283		

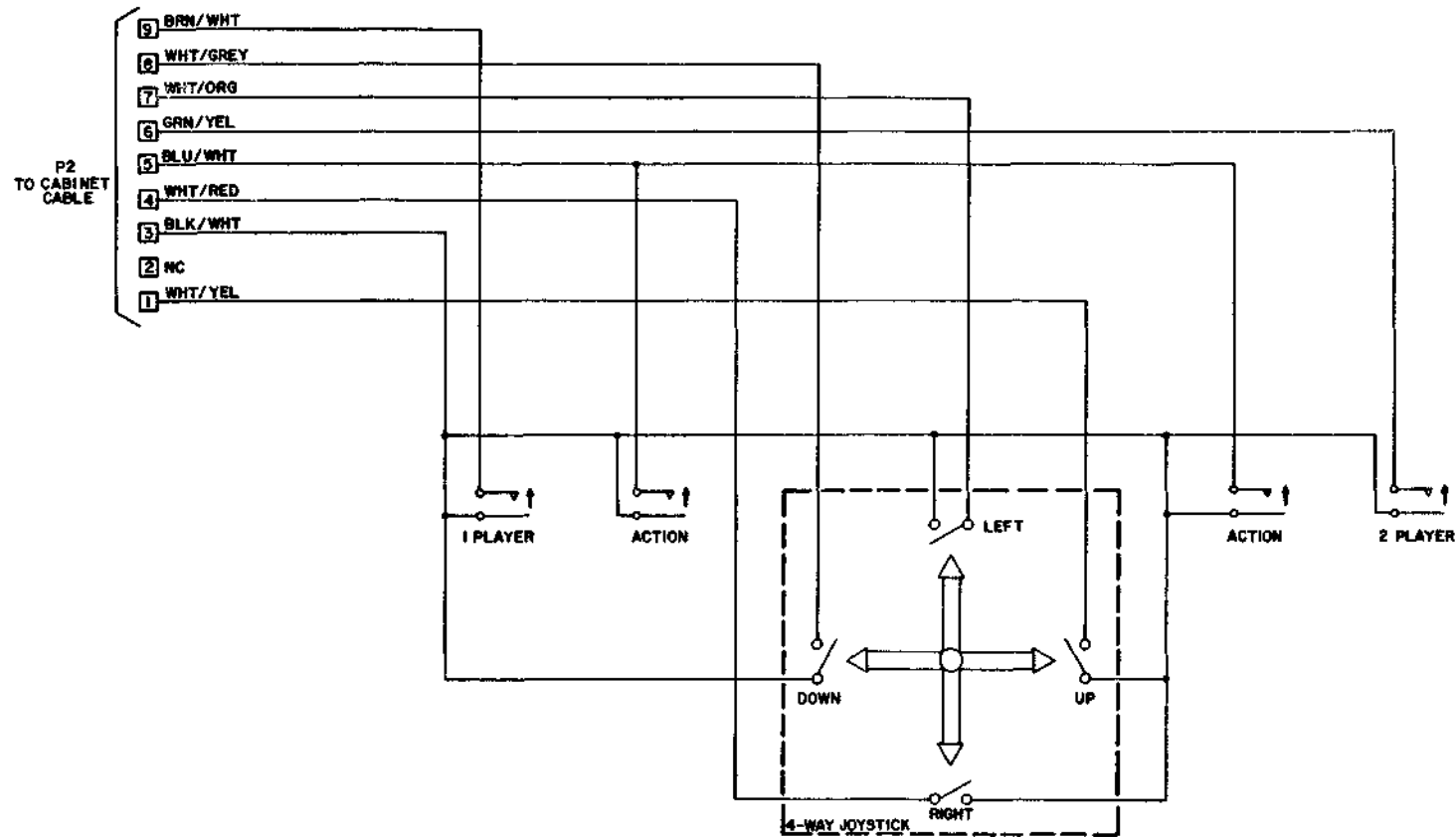

THESE DRAWINGS AND SPECIFICATIONS ARE THE EXCLUSIVE PROPERTY OF URL/ASTERN ELECTRONICS COMPANY. ISSUED IN STRICT CONFIDENCE AND SHALL NOT WITHOUT THE PRIOR WRITTEN PERMISSION OF UNIVERSAL RESEARCH LABORATORIES BE REPRODUCED, COPIED, OR USED FOR ANY PURPOSE WHATSOEVER EXCEPT THE MANUFACTURE OF ARTICLES FOR UNIVERSAL RESEARCH LABORATORIES, INC.

DR. T. NERAD 1/10/83

CHK: *[Signature]*

APP'D: *[Signature]*

SCALE: _____ MODEL: _____

DO NOT SCALE DRAWING

URL/ASTERN

UNIVERSAL RESEARCH LABORATORIES, INC.
 2700 W. WASHINGTON AVE. ST. LOUIS, MO. 63103
 TEL: (314) 241-1100 FAX: (314) 241-1101

NAME		WIRING DIAGRAM, BAGMAN CONTROL PANEL	
DWG	PART NO.	REV	
C	34C-2485-WD	A	
SIZE	SHEET	1	OF 1