



©!#?©!

Q*bert^{T.M.}

Instruction Manual

 **Gottlieb**
AMUSEMENT GAMES

165 W. Lake Street Northlake, IL 60164
(312) 562-7400 Telex 72-8463

A Columbia Pictures Industries Company 

Q*BERT (GAME GV-103A) INSTRUCTION MANUAL

TABLE OF CONTENTS

SEC.		PAGE
I.	INSTALLATION	1
II.	INITIALIZATION	3
III.	GAME OPERATION	3
IV.	GAME PLAY AND SCORING	4
V.	SOUND/SPEECH	6
VI.	GAME ADJUSTMENTS/OPTIONS	6
VII.	BOOKKEEPING AND SELF TEST	7
VIII.	GENERAL INFORMATION	9
IX.	THEORY OF OPERATION	11
X.	WIRING AND SCHEMATIC DIAGRAMS	12
XI.	PARTS INFORMATION	33

**WELLS GARDNER MONITOR,
SERVICE AND OPERATION MANUAL (Attached)**

WARNING: This equipment generates, uses, and can radiate radio frequency energy and if not installed and used in accordance with the instructions manual, may cause interference to radio communications. It has been tested and found to comply with the limits for a Class A computing device pursuant to Subpart J of Part 15 of FCC Rules, which are designed to provide reasonable protection against such interference when operated in a commercial environment. Operation of this equipment in a residential area is likely to cause interference in which case the user at his own expense will be required to take whatever measures may be required to correct the interference."

NOTICE

WARRANTY INFORMATION IS LOCATED ON THE INSIDE BACK COVER.

FOR SERVICE, CALL TOLL FREE: 1-800-323-9121; (ILLINOIS) 1-800-942-1620

I. INSTALLATION

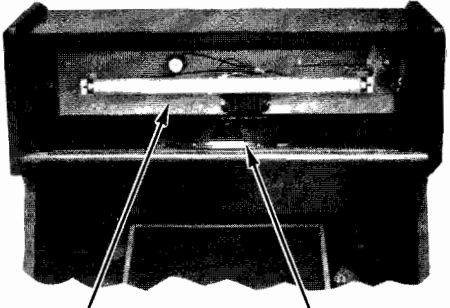

MA-376 ILLUMINATION ASSY.
MA-377 SPEAKER ASSY.

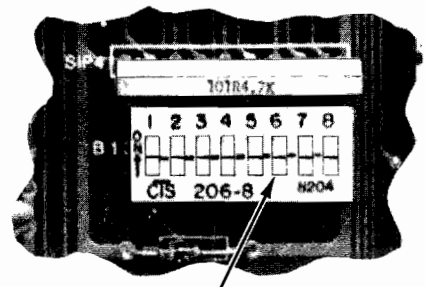

GAME ADJUSTMENT SWITCHES (PART OF AI LOGIC BOARD)

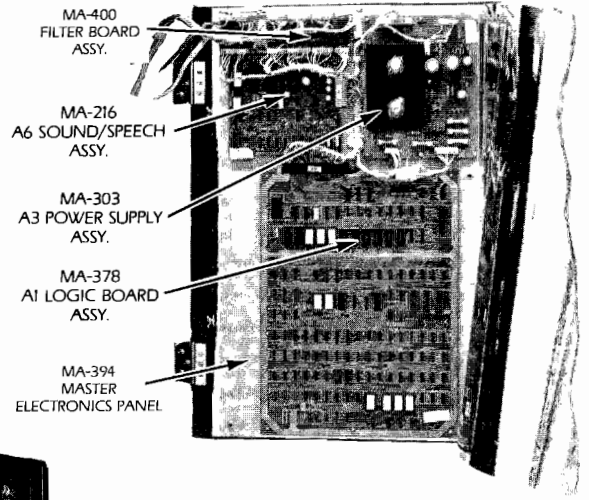

MA-400 FILTER BOARD ASSY.
MA-216 A6 SOUND/SPEECH ASSY.
MA-303 A3 POWER SUPPLY ASSY.
MA-378 AI LOGIC BOARD ASSY.
MA-394 MASTER ELECTRONICS PANEL

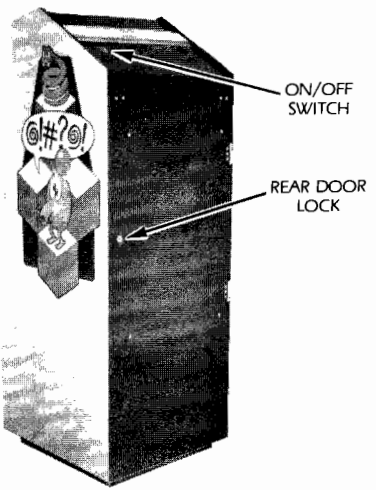

ON/OFF SWITCH
REAR DOOR LOCK

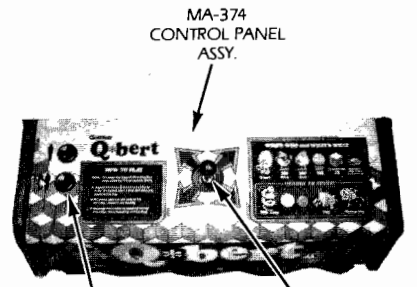
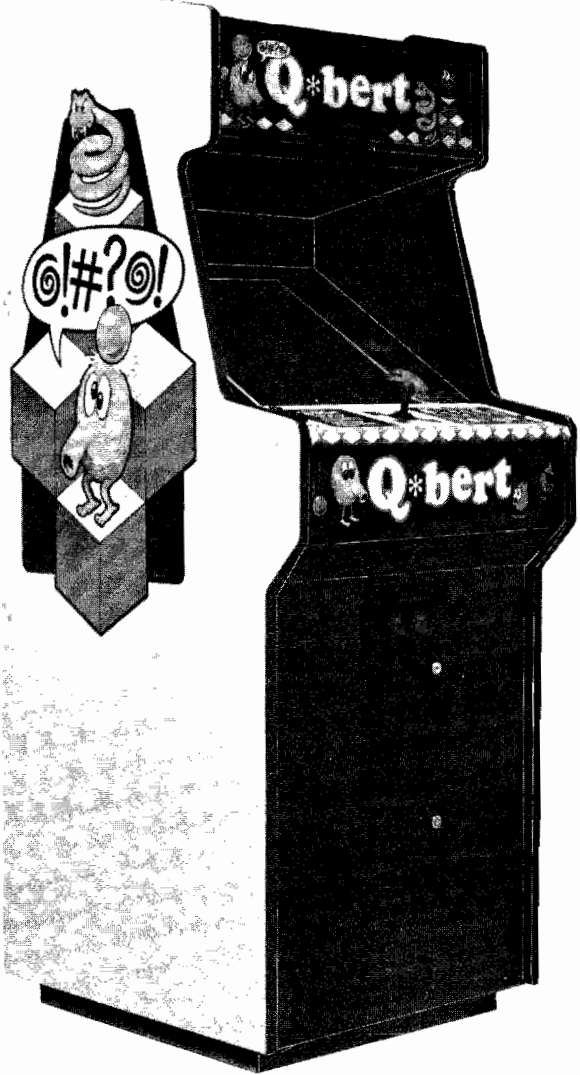

MA-374 CONTROL PANEL ASSY.
PLAYER SWITCHES (TYPICAL)
C-22458 JOYSTICK

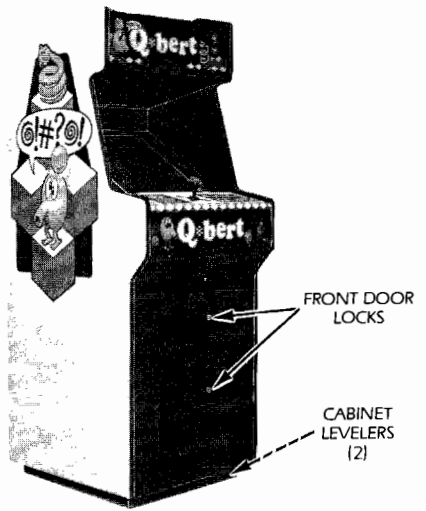

FRONT DOOR LOCKS
CABINET LEVELERS (2)

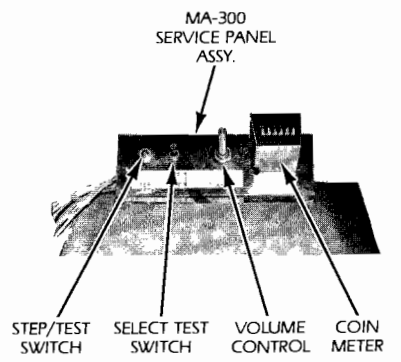

MA-300 SERVICE PANEL ASSY.
STEP/TEST SWITCH
SELECT TEST SWITCH
VOLUME CONTROL
COIN METER

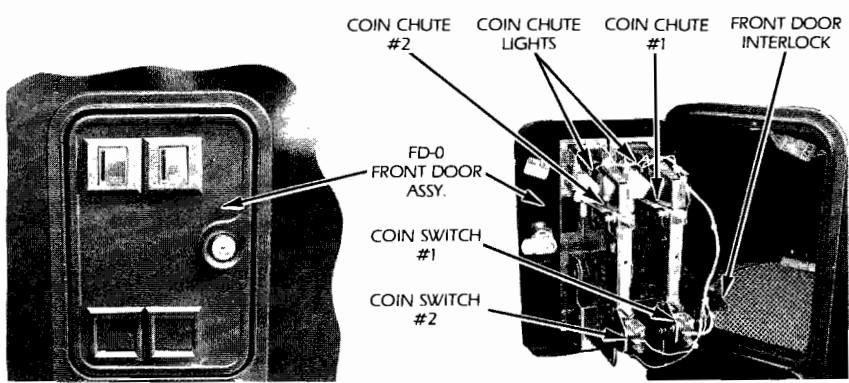

COIN CHUTE #2
COIN CHUTE LIGHTS
COIN CHUTE #1
FRONT DOOR INTERLOCK
FD-0 FRONT DOOR ASSY.
COIN SWITCH #1
COIN SWITCH #2

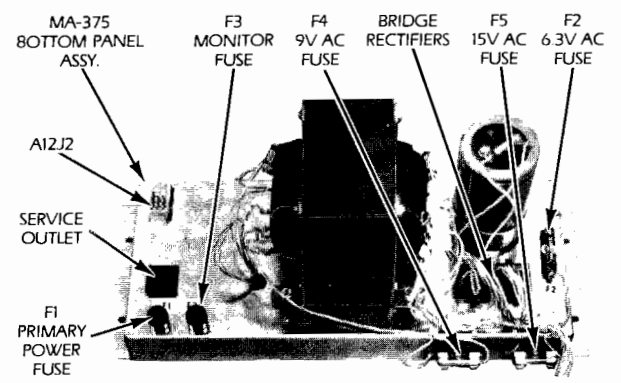

MA-375 BOTTOM PANEL ASSY.
A12J2
SERVICE OUTLET
F1 PRIMARY POWER FUSE
F3 MONITOR FUSE
F4 9V AC FUSE
BRIDGE RECTIFIERS
F5 15V AC FUSE
F2 6.3V AC FUSE

I. INSTALLATION

A. SET-UP

1. Carefully inspect the exterior of the game for any damage which might have occurred during shipment.
2. Unlock and open the rear cabinet door.
3. Check that all plug in connectors are seated firmly. The connectors are keyed so they will only go in one way.
4. Remove the binding strap from the line cord, and install the line cord plate in the groove provided (see photo).
5. Cabinet levelers (2) are stored within the cash box for shipping purposes. Install and adjust as necessary.

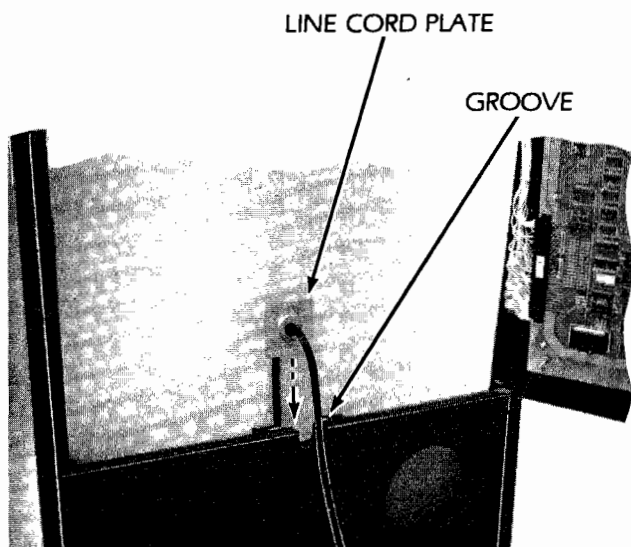

B. CHECK-OUT

1. Check that all cables are free of moving parts.
2. Check for any loose wires.
3. Check for loose solder or foreign matter on switches and power supply assemblies.
4. Be certain all fuses are seated firmly.
5. Be sure transformer wiring corresponds to the supply voltage.
6. Refer to section VI to make all the necessary game adjustments.
7. Reassemble the game.
8. Plug the line cord into a properly grounded 3-wire receptacle ONLY!!

C. CONTROL PANEL REMOVAL

1. Unplug the game.
2. Unlock and open the coin chute door.
3. Reach in through the coin chute door and remove the wing nut and flat washer from each of the two carriage bolts which secure the control panel to the game. Remove the carriage bolts.
4. Pull the control panel back, grasp it at the front edge as far back as it will go (approximately 1/4").
5. Raise the front of the control panel approximately one inch above its supports and lift the entire assembly high enough to disconnect plug A9J2/A9P2.
6. Remove the entire control panel assembly from the game.
7. The Joystick and leaf-switches are now accessible for removal or cleaning.

D. MONITOR REMOVAL

1. Unplug the game.
2. Perform the control panel assembly removal procedure (Section C).
3. Remove the outside shield, glass and monitor mask and put them aside in a secure place.
4. Unlock and open the rear cabinet door.
5. NOTE: The color monitor contains HIGH VOLTAGES delivering LETHAL quantities of energy. Do not attempt to service the monitor until you have shorted the anode plug on the picture tube to ground.
6. Disconnect the video plug A17J1, the monitor power supply plug A12J3/A12P3 and the ground wire from the monitor chassis.
7. From the rear of the game, remove the one nut and one washer from each of the four carriage bolts used to secure the monitor to the platform.
8. Remove the monitor from the rear of the game, being careful to clear all cables from the CRT neck.
9. For reassembly, reverse the above procedure.

II. INITIALIZATION, III. GAME OPERATION

II. INITIALIZATION

TURN GAME ON

Immediately, the coin chute lamps and the speaker marquee lamp will turn on.

AFTER A TEN SECOND DELAY

- A. The attract mode appears on the screen.

B. The playing field cycles through the follow.

1. High Game to Date screen
2. Instruction Set
3. Game Play Cycle

III. GAME OPERATION

A. GAME START

1. Insert coins into coin chute.
 - a. Coin chute tune is played.
 - b. Total credits are displayed on screen.
2. Press one or two player button to start game.
 - a. Demonstration scene displayed on screen.
 - b. Total Credits are decreased by one.
 - c. Game initializes.

B. FIRST PLAYER

1. The first player's score displays a zero.
2. The other player's display will be blank.

C. SECOND PLAYER

1. Additional player is indicated by the words "PLAYER 2" and a zero in the second player's display.

D. "Q*BERTS"/EXTRA "Q*BERTS"

1. Each player will begin with three "Q*Bert" lives. (Dependent on Option/Parameter settings.)
2. Extra "Q*Berts" are earned by achieving certain score levels. (Dependent on Option/Parameter settings.)

IV. GAME PLAY AND SCORING

HOW TO PLAY

The object of the "Q*Bert" game is to change the color of the top of the cubes to the designated color by hopping onto them. When all the cubes in the pyramid have been changed to the designated color, the screen will advance to the next Round, with "Q*Bert" starting back on the top cube. At the beginning of each Level, there will be a short demonstration cycle with the "Q*Bert" character hopping around four cubes to explain to the player the play action of each Level. Each Level consists of four Rounds.

The game play starts with the player-controlled "Q*Bert" character appearing at the top of the pyramid. The joystick will move "Q*Bert" from cube to cube by hopping in any of four diagonal directions. "Q*Bert" can move anywhere on the pyramid, but jumping off will kill him. Hopping on the rotating disk will take "Q*Bert" back to the top of the pyramid. In the first two Rounds "Q*Bert" will have to avoid touching the red and purple balls. These deadly objects drop randomly onto the second-from-the-top level and bounce downwards. The red balls will fall off the bottom but the purple ball will stop at the bottom and hatch into "Coily", the snake which chases "Q*Bert". To destroy the snake, lure him to the edge, then jump unto a disk. The disk will take "Q*Bert" back to the top and "Coily" will fall off, awarding 500 points.

Starting at the third Round, other characters come into play. The green characters or objects are safe to hop onto and will award points. All other objects are deadly to touch. In the third Round the red balls will stop falling, but two purple characters, "Ugg" and "Wrong-Way", will appear at the lower portion of the pyramid and travel sideways and upwards. They will not chase "Q*Bert" but will move randomly to get in "Q*Bert's" way. In the third Round and every Round after, based on an internal timer, a green ball will appear and bounce down from the top of the pyramid. Hopping "Q*Bert" onto the green

ball will award 100 points, and freeze all the characters on the screen for a few seconds, but "Q*Bert" will still be able to move to complete the color changes.

During the third Round of play, two green characters, "Slick" and "Sam", will appear, based on the internal timer. They will drop onto the second level from the top and hop randomly downwards. If they hop onto a cube that "Q*Bert" has already changed the color of, the cube will change to a different color, to thwart "Q*Bert". Hopping "Q*Bert" onto "Slick" or "Sam" will stop them and award 300 points.

Throughout the remaining Rounds, all the characters and objects will appear in random combinations with increasing speed.

To add variety to the game, the disks will change positions every Round, and in the higher Levels the number of disks will change. (See Round Progression Chart.)

During Level Two, the play action will increase in difficulty from changing the cubes to one color, to changing the color of the cubes twice. This means that each cube would have to be hopped on twice to change the pyramid to the designated color, completing the Round.

Starting at Level Three and for all remaining Rounds, and Levels, the play action will become more difficult. The object remains to change the cubes to the designated color, but if "Q*Bert" hops on any cube, that cube will change color. So even if the cube has been changed to the designated color, it will change again.

There are also Bonus points awarded at the end of each Round for successfully completing the Round. The Bonus for the completion of the First Round is 1,000 points. This Bonus will progressively increase each Round by 250 points to a maximum of 5,000 points at Level Five.

CONTROL PANEL INSTRUCTIONS

Goal: Change the tops of all cubes to a new color by hopping onto them.

- Joystick moves "Q*Bert" from cube to cube. Hopping onto a disk will take you back to the top.

- All green objects are safe to hit. All other objects are deadly.
- Destroy the snake by leading him to the edge, then jumping on a disk.
- Stay on pyramid! Only jump off to use a disk.

IV. GAME PLAY AND SCORING

ROUND PROGRESSIONS

The following chart lists round progressions for "Q*Bert".

Commencing with Level V all characters will appear in each subsequent round. The number of disks and the Round Completion Bonus will remain the same value for the rest of the game. The characters and play action will gain more speed with each increased level of play.

	ROUND	DISKS	CHARACTERS ON SCREEN	ROUND COMPLETION BONUS
LEVEL I	1	2	Red Balls, Coily	1000
	2	2	Red Balls, Coily	1250
	3	2	Coily, Green Ball, Ugg/Wrong way, Slick/Sam	1500
	4	2	Red Balls, Coily, Green Ball, Slick/Sam	1750
LEVEL II	1	3	Coily, Green Ball, Ugg/Wrong Way, Slick/Sam	2000
	2	3	Coily, Green Ball, Ugg/Wrong Way, Slick/Sam	2250
	3	2	Red Balls, Coily, Green Ball, Slick/Sam	2500
	4	2	Red Balls, Coily, Green Ball, Ugg/Wrong Way, Slick/Sam	2750
LEVEL III	1	4	Red Balls, Coily, Green Ball, Slick/Sam	3000
	2	4	Coily, Green Ball, Ugg/Wrong Way, Slick/Sam	3250
	3	3	Red Balls, Coily, Green Ball, Ugg/Wrong Way, Slick/Sam	3500
	4	3	Red Balls, Coily, Green Ball, Ugg/Wrong Way, Slick/Sam	3750
LEVEL IV	1	6	Red Balls, Coily, Green Ball, Slick/Sam	4000
	2	6	Red Balls, Coily, Green Ball, Ugg/Wrong Way, Slick/Sam	4250
	3	5	Red Balls, Coily, Green Ball, Slick/Sam	4500
	4	4	Red Balls, Coily, Green Ball, Ugg/Wrong Way, Slick/Sam	4750
LEVEL V	1	7	In Level V all characters will appear in each Round	4750
	2	6		5000
	3	6		5000
	4	5		5000
LEVEL VI THRU LEVEL IX	1	5	All characters will appear in each Round in Level VI thru Level IX	5000
2	5	5000		
3	5	5000		
4	5	5000		

SCORING

- Luring "Coily" off the edge
Scores 500 points and clears pyramid of characters
- Hopping onto "Slick" or "Sam"
Scores 300 points
- Hopping onto Green Ball
Scores 100 points and freezes characters but not "Q*Bert"
- Changing cubes to designated color
Scores 25 points
- Changing cubes to intermediate color (in Level II or Up)
Scores 15 points
- Unused disks
Scores 50 points
- Round Completion Bonus
See Round Progression Chart

WHO'S WHO and WHAT'S WHAT



Q*Bert



300 Slick



300 Sam



Freezes board
100



For target color
25



Hopping on takes Q*Bert back to the top

DEADLY TO TOUCH!



500 Coily



Ugg



Wrong-way

V. SOUND/SPEECH, VI. GAME ADJUSTMENTS / OPTIONS

V. SOUND/SPEECH

ATTRACT MODE

SPEECH

"HELLO, I'M TURNED ON"

OCCURENCE

When game is powered up.

GAME MODE

SPEECH

(Garbled Nonsense Speech)

"BYE, BYE"

OCCURENCE

When "O*Bert" is killed.

When the characters "Slick/Sam" and "Ugg/Wrong Way" are present.

When player has finished entering his initials on high score table.

VI. GAME ADJUSTMENTS/OPTIONS

A. CONTROL BOARD SWITCH ADJUSTMENTS

SWITCH 1 _____ **DEMONSTRATION MODE***
ON INFINITE LIVES
OFF NORMAL PLAY

SWITCH 2 _____ **ATTRACT PLAY**
ON NO SOUND
OFF SOUND

SWITCH 3 _____ **NORMAL/FREE**
ON FREE PLAY
OFF NORMAL GAME

SWITCH 4 _____ **GAME MODE**
ON COCKTAIL
OFF UPRIGHT

SWITCH 5 _____ **NOT USED**

SWITCH 6 _____ **KICKER**
ON KICKER ON
OFF KICKER OFF

SWITCH 7 _____ **NOT USED**

SWITCH 8 _____ **NOT USED**

*IN DEMONSTRATION MODE THE PLAYER WILL HAVE INFINITE LIVES AND CAN PROGRESS THROUGH THE ROUNDS BY HITTING EITHER START BUTTON.

B. SOUND ADJUSTMENTS

The audio output is controlled by the potentiometer mounted on the service panel assembly (located inside the coin mechanism door).

Turning the potentiometer counter-clockwise will decrease the volume. Turning it clockwise will increase the volume.

IMPORTANT: Each of the potentiometers installed on the Sound/Speech board have been factory adjusted. The potentiometer settings should never be changed when performing the recommended calibration procedure.

C. MONITOR ADJUSTMENTS

Normally, few if any adjustments are required for proper monitor operation. However, after any major repairs to the monitor chassis refer to the attached monitor manual.

VII. BOOKKEEPING AND SELF TEST

BOOKKEEPING

The battery back-up bookkeeping functions of Q*Bert (GV-103) are contained in Self Test steps 3 and 4. These are in addition to the electro-mechanical coin counter located inside the front door panel. Every time a coin is inserted into a coin slot, the counter is energized, incrementing the count.

SELF TEST

The self-test consists of six functions which may be used to identify problems in the video system and to change program parameters.

The self-test mode is entered by setting the self-test toggle switch located inside the cash door to "TEST". A selection of available tests is displayed on the monitor. To return to the GAME mode at any time, the operator needs only to set the toggle switch back to "GAME".

Selection of tests is done with the push button switch labeled "SELECT". Upon entering the test mode, a flashing arrow points to the first test selection. Momentarily depressing the "SELECT" button will advance through each selection one by one.

When the arrow is pointing to the desired test, the operator may begin that test by pressing the "SELECT" button and holding it down until the test appears on the screen.

Once a test has been selected, the operator can return to the selection list by holding down the select switch until it re-appears. The eight tests are as follows:

1. MONITOR ADJUSTMENT

Four patterns can be displayed on the screen for adjusting monitor color, brightness, contrast and convergence. The patterns are: Color bars, a cross-hatch, a gray scale, and a dot pattern. By momentarily pressing the select switch, the operator may cycle through the four patterns.

2. DIP SWITCHES

A functional description of the eight Dip Switches located on the Logic Board Assy. is displayed. Changing any switch will cause an immediate update of the description displayed on the screen.

3. DISTRIBUTIONS

Selecting this test will first display a distribution option. The distributions can be reset to zero by pressing either start button, and then pressing the SELECT button momentarily. Following the latter, a cleared distribution screen will be displayed; or the distribution screen can be viewed without clearing it by pressing the SELECT button momentarily when in this test mode. The distribution screen will show three categories of counts — 1) Level/Round; 2) Time; 3) Score. These categories, used with the coin meter count, can be used to derive the game percentages and averages.

The categories are presented in three vertical pairs of columns displaying the level of category and the number of players to attain that level. The left category is a list of the Levels and Rounds up to Level 3, Round 4. Next to each Level/Round is the number of players to reach that Level/Round. The middle two columns are a list of game durations in 45 second increments and the number of players to last that long next to it. The right two columns are a category of players scores in increments of 3000 points and the number of players to attain that score level.

At the bottom of each category will be displayed the number of players to go beyond the defined levels. The number of players in each category level are independent of the other categories, so each player will be listed once each for Level, Time and Score. The number of players in each category level are given in 4 digit values only, so the distribution table should be reset every two weeks or so to insure that meaningful information will be contained in it.

4. OPTIONS/PARAMETERS

This test will allow the operator to view and change all game options on one screen. During this test the screen will display seven operator adjustable options. Pressing the "SELECT" button momentarily will advance the arrow to the next option desired. When the arrow is pointing to the appropriate option, the

VII. BOOKKEEPING AND SELF TEST

operator can then adjust that option by pressing either of the control panel start buttons, to select the desired value for each option.

- A. Reset High Score Table — Pressing either start button will reset all 23 high scores to random values and initials starting at 3000 points for No. 1.
- B. Factory Preset — Using this option will reset all the following options to the factory recommended levels: 1 Coin/1 Credit, 3 Lives, Normal Difficulty, 1st Extra Life at 8000 Points, Each additional life at each subsequent 14000 Points.
- C. Coin/Credit Combinations — Pressing either Start button will cycle thru three coin combinations:
 - 1) 1 coin = 1 play
 - 2) 1 coin = 2 play
 - 3) 2 coin = 1 play
- D. Lives Per Game — Pressing either Start button will cycle thru three choices; 3 Lives Per Game, 4 Lives Per Game, 5 Lives Per Game.
- E. Difficulty — Two choices may be selected with either Start button; Normal or Hard.
- F. 1st Extra Life — There are six choices, from 6000 Points to 11000 Points, that will be displayed by pressing either Start button. Any value can be chosen to award the first extra life by stopping on that choice and then selecting the next option.
- G. Each Additional Life — There are six choices, from 12000 Points to 17000 Points, that will cycle thru by pressing either Start button. Any value can be selected to award additional lives at each subsequent Point level chosen.

5. MEMORY

For each RAM memory chip; a green check (✓) or red (x) appears signaling that the chip is good or bad respectively.

For each ROM memory chip, a check sum is displayed. If you have a suspect ROM, refer to your distributor for the correct check sum number.

6. SWITCHES

A colored square is displayed for each player button. Pressing a button causes the appropriate square to change color. For each coin mechanism, a digit is displayed (initially 0). Inserting a coin into a coin chute will increment the appropriate value without affecting the coin meter.

7. SOUND TEST

After selecting this test a count will appear on the screen representing the various sounds that are produced by the Q*Bert game. There will be 36 different sounds produced and the screen count will stop at 41. Pressing either Start button will suppress all sound output and speed up the count so a particular sound can be sought out and checked.

Note: The count on the screen represents the binary signal code that will be sent to the A6 Sound/Speech board through the six sound input lines on the A6J1 connector. When executing the Sound Test sequence, there will be no sounds produced on counts 16, 29, 30, 31 and 32. There are no sounds assigned to these numbers.

8. OBJECT PRIORITY

Visual inspection must be used to determine the priority of two or more objects occupying the same area of the screen; that is, which objects appear to be in front of others and which are behind.

A total of 62 identical objects are placed on the screen in 4 rows. Each object overlaps another such that the first object appears to be in front, and succeeding objects appear to be placed behind all previous ones. When this display is completed, the procedure is repeated such that each new object appears to be in front of all the previous ones.

VIII. GENERAL INFORMATION

A. PRINTED CIRCUIT BOARDS ARE DESIGNATED AS FOLLOWS:

- A1 Logic Board Assy.
- A3 Power Supply Assy.
- A6 Sound/Speech Assy.
- A8 Filter Board

B. WIRE COLORS ARE SHOWN AS NUMBERS:

0 Black	5 Green
1 Brown	6 Blue
2 Red	7 Purple
3 Orange	8 Slate
4 Yellow	9 White

For example, 688 is a BLUE- SLATE-SLATE striped wire.

C. FUSES

BOTTOM PANEL

F1	Primary Power		4 Amp SLO-BLO
F2	6.3 VAC		3 Amp SLO-BLO
F3	Monitor		2 Amp SLO-BLO
F4	9 VAC		10 Amp SLO-BLO
F5	15 VAC		1 Amp SLO-BLO
F6	Knocker	+30VDC	1 Amp SLO-BLO

POWER SUPPLY ASSY. (A3)

F11	+5VDC Source		5 Amp SLO-BLO
F21	Sound/Speech Assy.	+30VDC	1½ Amp SLO-BLO
F31	Sound/Speech Assy.	+12VDC	¼ Amp SLO-BLO
F32	Sound/Speech Assy.	-12VDC	¼ Amp SLO-BLO
F41	Coin Meter	+20VDC	1 Amp SLO-BLO

VIII. GENERAL INFORMATION

POWER SUPPLY SPECIFICATIONS

LOCATION	VOLTAGE	PROTECTION
Logic Board Assy.	+5VDC	Voltage adjustable. 6Amps over-voltage protection and fused for over-current protection.
Sound/Speech Board	+30VDC	1.5Amps fused for over-current protection. The reference for this circuit is a 1N5363 + 30VDC Zener controlling the base of an emitter follower pass transistor.
Sound/Speech Board	+12VDC -12VDC	100 milliamps fused for over-current protection. The plus and minus 12 volts supplies are the 7812 and 7912 IC regulators respectively.
Coin Meter	+20VDC	Full wave rectified unfiltered voltage, fused for over-current protection.
Coin Chute Lights	+4.5VDC	Full wave rectified unfiltered voltage, fused for over-current protection.
Monitor and Marquee	100VAC or 115VAC, 60HZ	Isolated, fused AC voltage.

IX. THEORY OF OPERATION

INTRODUCTION

The character based graphics system designated GG-III has two main subdivisions. The first subdivision is the Central Processor Unit (CPU) which has three partitions:

- a. Microprocessors
- b. Memory
- c. Input and Output ports (I/O)

The Intel 8088 microprocessor is used and 32K bytes of memory is reserved for programming space and has 5 input ports and 5 output ports. The second subdivision is the video state machine which generates and controls the video signal to the monitor. The state machine has three partitions:

- a. System Clock (CLK)
- b. Foreground generator (FGND)
- c. Background generator (BGND)

The system clock is driven by a 20MHZ crystal, divided down for a 5MHZ dot clock.

All inputs and outputs including the video control and general purpose I/O are memory-mapped, (i.e. everything within the system can be addressed in a single segment of 64K addresses as memory).

The video control unit is divided into an "object-oriented" foreground driver and "character-oriented" background driver. The screen resolution is 256 pixels horizontally, and 240 lines vertically for both foreground and background. The CPU communicates with the foreground driver and background driver by writing data into the

designated memory areas in a certain format. The foreground is designed to display moving objects on the screen with a minimum overhead to the processor. The game programs will only have to specify the vertical and horizontal position and the object select number to the foreground driver. The background video supplements the foreground with relatively static figures on the screen. The CPU specifies all the character positions on the screen with desired "character" patterns.

A 5MHZ system clock drives a 9 bit horizontal dot counter and an 8 bit vertical line counter. The horizontal counter counts from 0 to 255 during active scan line and 256 to 317 during horizontal blanking time. When the horizontal counter reaches 317, the horizontal counter resets to 0. At the beginning of the horizontal blanking time (horizontal counter = 256) it increments the vertical counter. The vertical counter counts from 0 to 239 during active vertical scan time and 240 to 255 during vertical blanking time.

The battery backup system supports two battery RAM's that store all of the bookkeeping functions. The battery is maintained at a +3.6V reference by a trickle charge supplied on the logic board regulated by a current limiting resistor. If the AC power to the game is interrupted, the battery allows the RAM's to store the data contained in the Distributors table and the Options/Parameters screen.

X. WIRING AND SCHEMATIC DIAGRAMS, PARTS LISTS

TABLE OF CONTENTS

	PAGE
LOGIC BOARD ASSY. (A1)	
COMPONENT LOCATION AND PARTS LIST	13
SCHEMATIC DIAGRAM (SHEET 1 OF 3)	16
SCHEMATIC DIAGRAM (SHEET 2 OF 3)	18
SCHEMATIC DIAGRAM (SHEET 3 OF 3)	21
POWER SUPPLY ASSY. (A3)	
COMPONENT LOCATION AND PARTS LIST	24
SCHEMATIC DIAGRAM	25
SOUND/SPEECH ASSY. (A6)	
COMPONENT LOCATION AND PARTS LIST	27
SCHEMATIC DIAGRAM	28
PRIMARY POWER/FILTER BOARD/ INTERCONNECTION DIAGRAM	30

X. WIRING AND SCHEMATIC DIAGRAMS, PARTS LISTS

LOGIC BOARD ASSY. (A1), COMPONENT LOCATION

LOGIC BOARD ASSY. (A1), PARTS LIST

MISCELLANEOUS ELECTRONIC COMPONENTS

REFERENCE	DESCRIPTION	PART NO.
Bat. 1	Battery, 3.6V	XO-458
C1-C16	Capacitor, 0.1 UF 50V AX. CR. +80%-20%	XO-230
C25	Capacitor, 100 UF, 25V EL-AX	XO-212
C26	Capacitor, 0.1 UF, 50V AX. CR. +80%-20%	XO-230
C27	Capacitor, 100 UF, 25V EL-AX	XO-212
C31-34	Capacitor, 0.1 UF, 50V AX. CR. +80%-20%	XO-230
C51	Capacitor, 100 PF, 100V CMD 5%	XO-198
C52	Capacitor, 0.1 UF, 100V CMD 5%	XO-196
ALL UNMARKED CAPACITORS	.01 UF, 50V AX. CR. +80%-20%	XO-229
ALL UNMARKED UNMARKED CAPACITORS	10 UF, 25V AX. TANT. 10%	XO-127
D2	Diode, 1N4454	XO-275
D4	Diode, 1N4733A	XO-274
D81	Diode, 1N4148	XO-261
Q1-Q4	Transistor, 2N6044	XO-120
Q81-Q87	Transistor, MP5A70	XO-309
R1-R16	Resistor, 470 OHM, 5% 1/4W	XO-35
R37, R38	Resistor, 330 OHM, 5% 1/4W	XO-34
R39	Resistor, 130 OHM, 5% 1/4W	XO-172
R40	Resistor, 270 OHM, 5% 1/4W	XO-68
R41, R42	Resistor, 510 OHM, 5% 1/4W	XO-25
R43	Resistor, 130 OHM, 5% 1/4W	XO-172
R44, R45	Resistor, 1K OHM, 5% 1/4W	XO-5
R51, R52	Resistor, 330 OHM, 5% 1/4W	XO-34
R53, R54, R56	Resistor, 1K OHM, 5% 1/4W	XO-5
R57, R58	Resistor, 560 OHM, 5% 1/4W	XO-36
R59-R61	Resistor, 1K OHM, 5% 1/4W	XO-5
R63, R64	Resistor, 1K OHM, 5% 1/4W	XO-5
R70	Resistor, 1K OHM, 5% 1/4W	XO-5
R73, R74	Resistor, 1K OHM, 5% 1/4W	XO-5
R76-R80	Resistor, 1K OHM, 5% 1/4W	XO-5
R81	Resistor, 820 OHM, 5% 1/4W	XO-174
R82	Resistor, 100 OHM, 5% 1/4W	XO-28
R83, R84	Resistor, 15 OHM, 5% 1/4W	XO-171
R85	Resistor, 180 OHM, 5% 1/4W	XO-24
R86, R87	Resistor, 15 OHM, 5% 1/4W	XO-171
R88	Resistor, 180 OHM, 5% 1/4W	XO-24
R89, R90	Resistor, 15 OHM, 5% 1/4W	XO-171
R91	Resistor, 180 OHM, 5% 1/4W	XO-24
R92	Resistor, 1K OHM, 5% 1/4W	XO-5
R93	Resistor, 2K OHM, 5% 1/4W	XO-14
R94	Resistor, 1K OHM, 5% 1/4W	XO-5
R95	Resistor, 470 OHM, 5% 1/4W	XO-35
R96	Resistor, 240 OHM, 5% 1/4W	XO-173
R97	Resistor, 2K OHM, 5% 1/4W	XO-14
R98	Resistor, 1K OHM, 5% 1/4W	XO-5
R99	Resistor, 470 OHM, 5% 1/4W	XO-35
R100	Resistor, 240 OHM, 5% 1/4W	XO-173
R101	Resistor, 2K OHM, 5% 1/4W	XO-14
R102	Resistor, 1K OHM, 5% 1/4W	XO-5
R103	Resistor, 470 OHM, 5% 1/4W	XO-35
R104	Resistor, 240 OHM, 5% 1/4W	XO-173
SIP 1, SIP 2, SIP 4	Resistor, Dip. 4.7K, 9 Pin	XO-492
SIP 71, SIP 72, SIP 73	Resistor, Dip. 1K, 9 Pin	XO-493
X-TAL 1	Crystal, 15 MHZ	XO-482
XTAL 51	Crystal, 20 MHZ	XO-494
	Dip Switch	XO-505
	20 Pin Dip Socket	XO-491
	22 Pin Dip Socket	XO-467
	24 Pin Dip Socket	XO-529
	28 Pin Dip Socket	XO-536
	40 Pin Dip Socket	XO-530

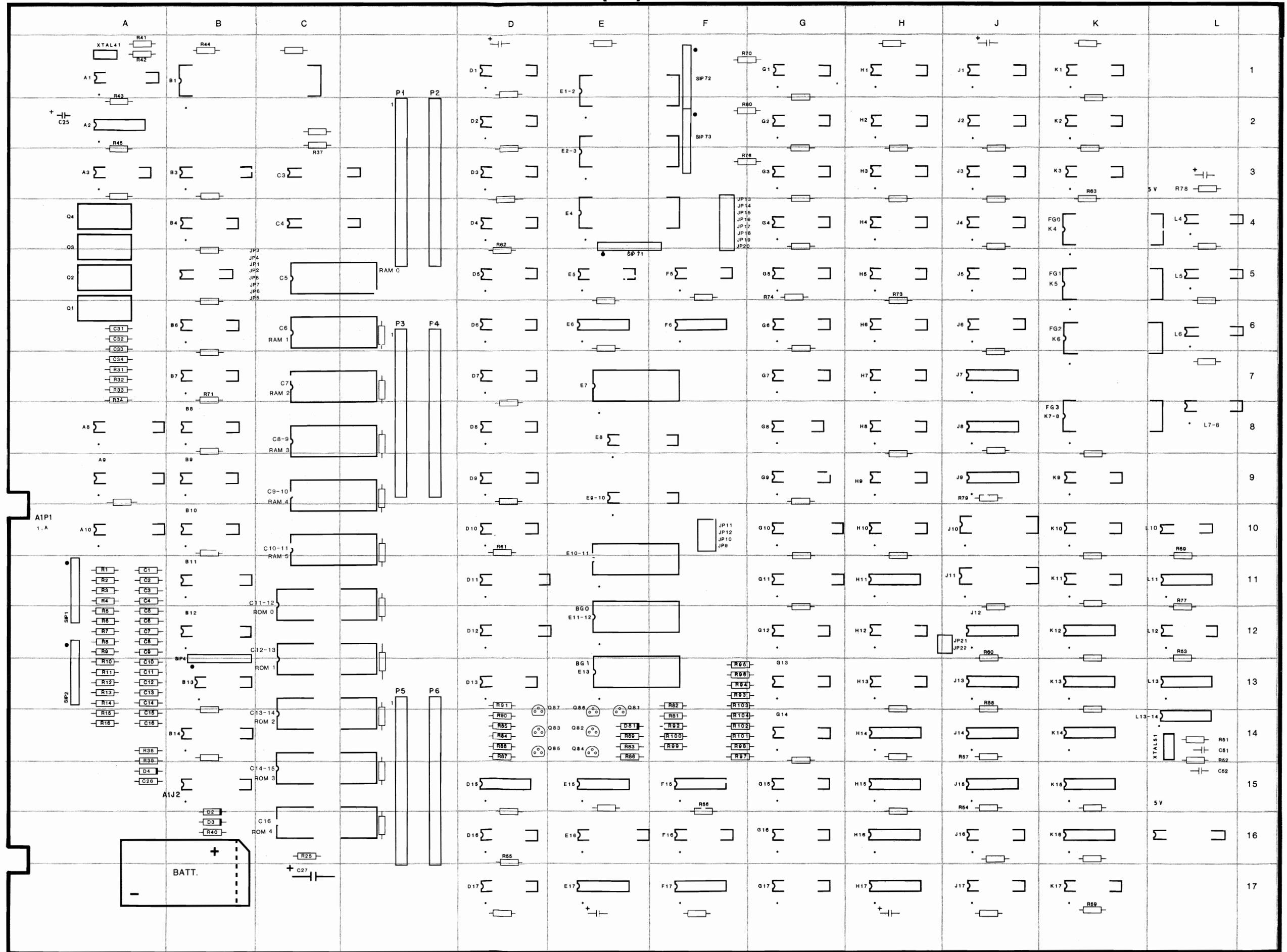

X. WIRING AND SCHEMATIC DIAGRAMS, PARTS LISTS

LOGIC BOARD ASSY. (A1),
PARTS LIST (CONT.)

INTEGRATED CIRCUITS

REFERENCE	DESCRIPTION	PART NO.	REFERENCE	DESCRIPTION	PART NO.
A1	Logic Board Assy.	MA-378	G7	74LS157 Quad 2-input multiplexer	XO-114
A2	8284 CLK Driver	XO-478	G8	74LS74 Dual D-type flip flop	XO-434
A3	74LS02 Quad 2-input "NOR" gate	XO-428	G9	74LS157 Quad 2-input multiplexer	XO-124
AB, A9, A10	74161 Synchronous 4-bit counter	XO-192	G10	74LS245 Octal bus transceiver	XO-79
B1	74LS377 Octal "D" Flip Flop	XO-97	G11	74LS374 Octal D-type flip flop	XO-96
B3	8088 CPU	XO-490	G12	74LS157 Quad 2-input multiplexer	XO-390
B4	74LS373 Octal D-type flip flop	XO-445	G13, G14, G15	74B9 64-bit RAM	XO-88
B5	74LS367 Hex 3-state buffer	XO-444	H1, H2, H3, H4	74LS174 Hex D flip flop	XO-442
B6	74LS08 Quad 2-input "AND" gate	XO-86	H5, H6	74LS189 64-bit RAM	XO-89
B7	74HC138 Decoder/demultiplexer	XO-190	H15	74LS161 Synchronous presettable binary counter	XO-488
B8, B9, B10	74LS139 Dual 1 of 4 decoder	XO-419	H16, H17	74LS157 Quad 2-input multiplexer "NAND" gate	XO-432
B11, B12, B14	74LS138 1 of 8 decoder	XO-437	J1, J2, J3	74LS30 8 input "NAND" gate	XO-435
C3	74LS240 Octal Buffer/line driver	XO-91	J4, J5, J6	74LS379 Dual D-type flip flop	XO-98
C4	74LS373 Octal D-type flip flop	XO-91	K1, K2, K3	74LS379 Dual D-type flip flop	XO-98
C5	74LS245 Octal Bus transceiver	XO-79	K4	FG0 2764-3 BK x 8 EPROM	XO-489
C6	RAM 6 6116LP-4	XO-191	K5	FG1 2764-3 BK x 8 EPROM	XO-489
C7	RAM 2 2128-2	XO-195	K6	FG2 2764-3 BK x 8 EPROM	XO-489
C8-9	RAM 3 2128-2	XO-195	K7-8	FG3 2764-3 BK x 8 EPROM	XO-489
C11-12	ROM 1/2 2764 BK x 8 EPROM	XO-489	K9, K10, K11	74LS157 Quad 2-input multiplexer	XO-390
C12-13	ROM 1 2764 BK x 8 EPROM	XO-489	K12	74LS260 Dual 5-input "NOR" gate	XO-93
C13-14	ROM 2 2764 BK x 8 EPROM	XO-489	K13	74LS32 Quad 2-input "OR" gate	XO-433
D1	74LS139 Dual 1 of 4 Decoder	XO-419	K14	74LS08 Quad 2-input "AND" gate	XO-86
D2, D3, D4, D5, D6, D7, D8, D9, D10	74157 Quad 2-input multiplexer	XO-114	K15	74S04 Hex inverter	XO-400
D11	74LS374 Octal D-type flip flop	XO-96	K16	74LS20 Dual 4-input "NAND" gate	XO-430
D12	74LS244 Octal buffer/line driver	XO-117	K17	74LS161 Synchronous presettable binary counter	XO-488
D13	74LS157 Quad 2-input multiplexer	XO-390	L4, L5, L6, L7	74LS166 8-bit shift register	XO-391
D15	74LS86 Quad 2-input exclusive "OR" gate	XO-435	L10	74LS74 Dual flip flop	XO-434
D16	74LS283 4-bit binary full adder	XO-95	L11	74LS20 Dual 4-input "NAND" gate	XO-430
D17	74LS161 Synchronous presettable binary counter	XO-488	L12	74LS161 Synchronous presettable binary counter	XO-440
E1-2, E2-3, E4	93419 64 x 9 bipolar RAM	XO-99	L13	74S74 Dual D-type pos. edge trig. flip flop (T. I. only)	XO-87
E5	74LS283 4-bit binary full adder	XO-95	L13-14	74S04 Hex inverter	XO-400
E6	74LS30 8-input "NAND" gate	XO-432			
E7	4801 1K x 8 RAM	XO-193			
E8, E9-10	74LS245 Octal Bus Transceiver	XO-79			
E10-11	4801 1K x 8 RAM	XO-193			
E11-12	2732A (BG1) 4K x 8 EPROM	XO-485			
E13	2732A (BG1) 4K x 8 EPROM	XO-485			
E15	74LS86 Quad 2-input exclusive "OR" gate	XO-435			
E16	74LS273 8-bit register	XO-94			
E17	74LS20 Dual 4-input "NAND" gate	XO-430			
F5	74LS283 4-bit binary full adder	XO-95			
F6	74LS32 Quad 2-input "OR" gate	XO-433			
F15	74LS04 Hex inverter	XO-418			
F16	74LS161 Synchronous presettable binary counter	XO-488			
F17	74LS86 Quad 2-input exclusive "OR" gate	XO-435			
G1, G2, G3, G4, G5, G6	74LS157 Quad 2-input multiplexer	XO-390			
	74LS161 Synchronous presettable binary counter	XO-440			

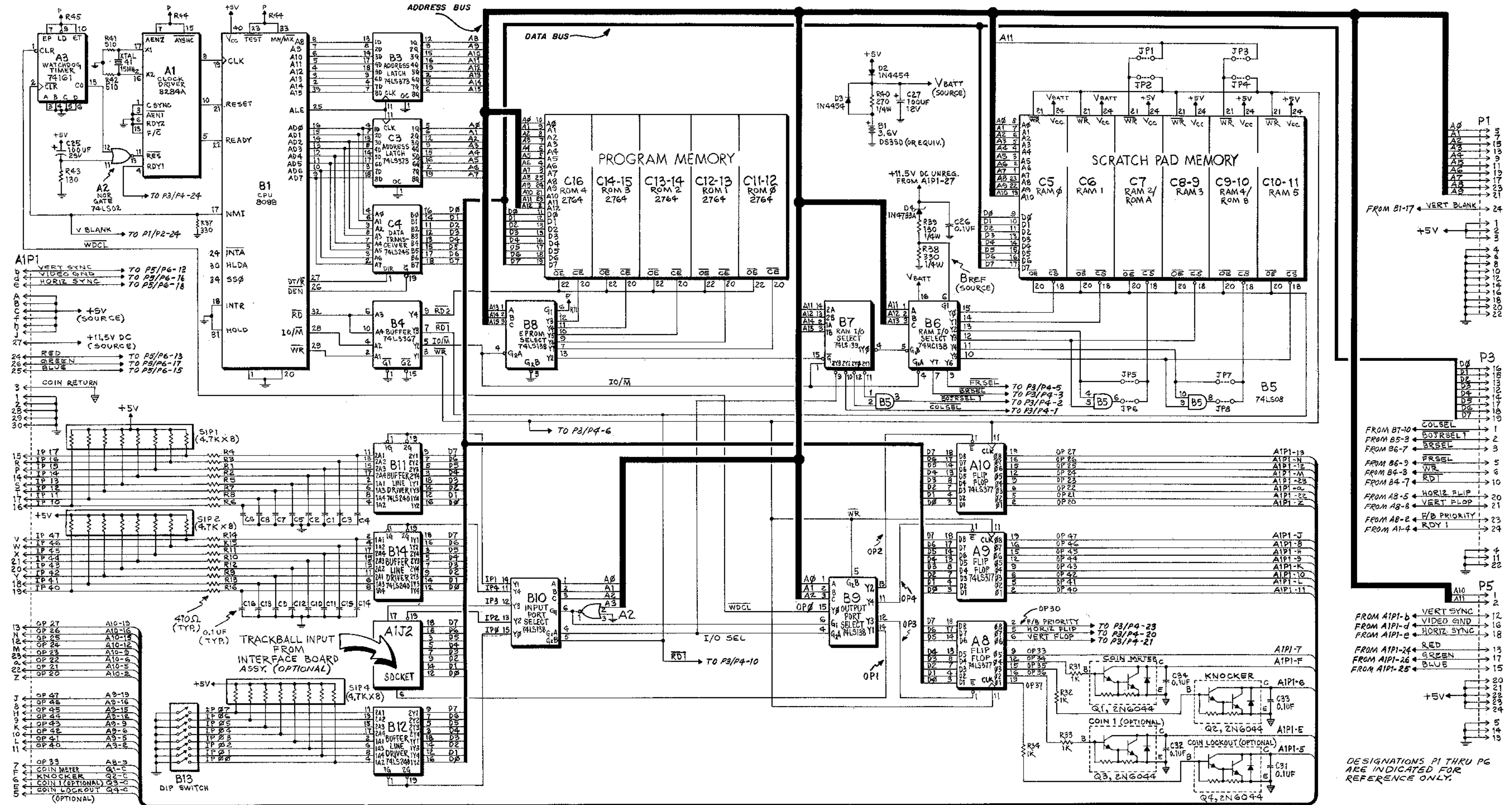

DESIGNATIONS P1 THRU P6 ARE INDICATED FOR REFERENCE ONLY.

X. WIRING AND SCHEMATIC DIAGRAMS, PARTS LISTS

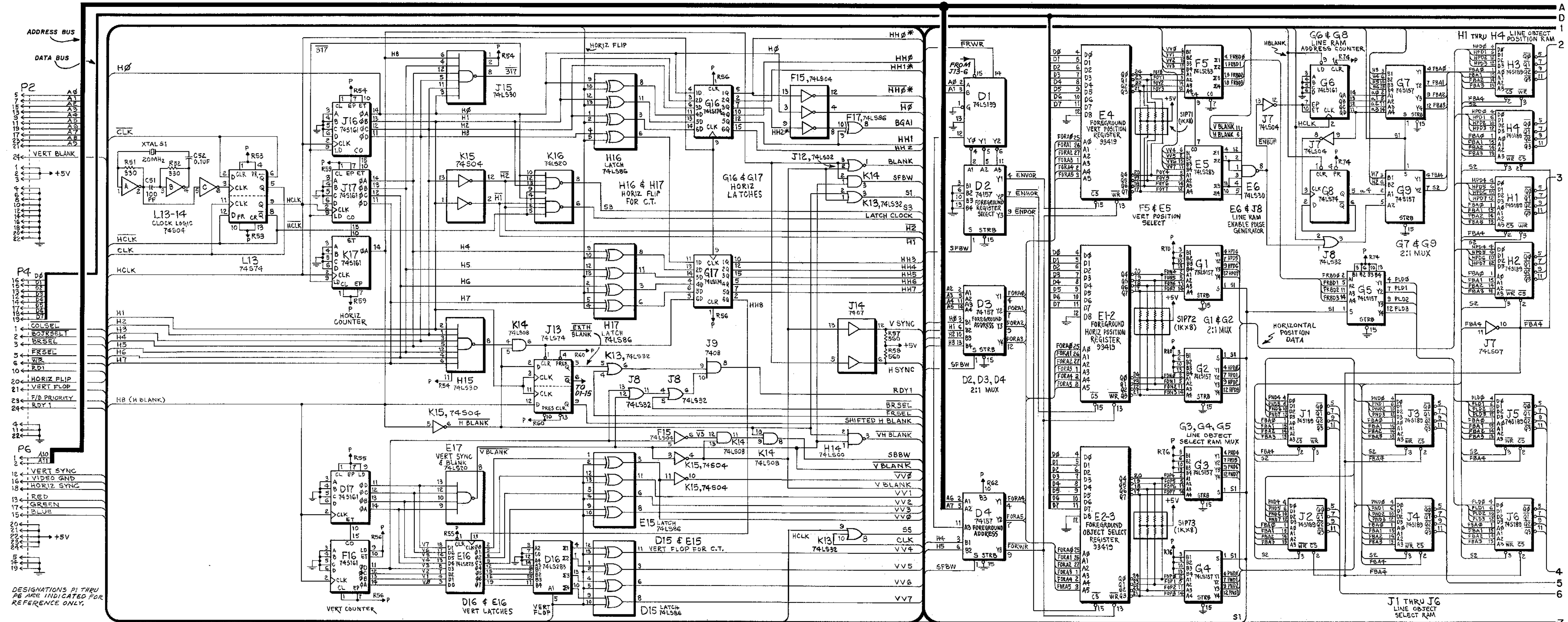

LOGIC BOARD ASSY. (A1), SCHEMATIC DIAGRAM, SHEET 2 OF 3

X. WIRING AND SCHEMATIC DIAGRAMS, PARTS LISTS

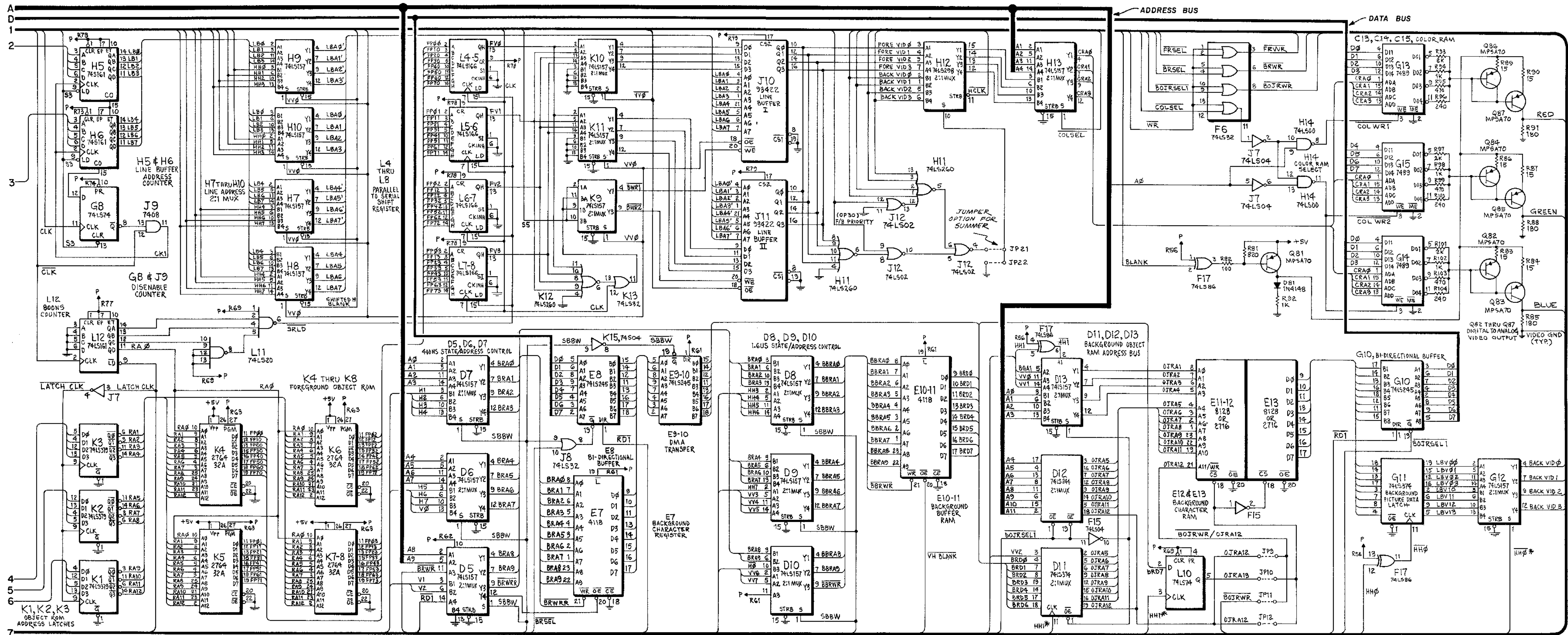

LOGIC BOARD ASSY. (A1), SCHEMATIC DIAGRAM, SHEET 3 OF 3

X. WIRING AND SCHEMATIC DIAGRAMS, PARTS LISTS

POWER SUPPLY ASSY. (A3), COMPONENT LOCATION

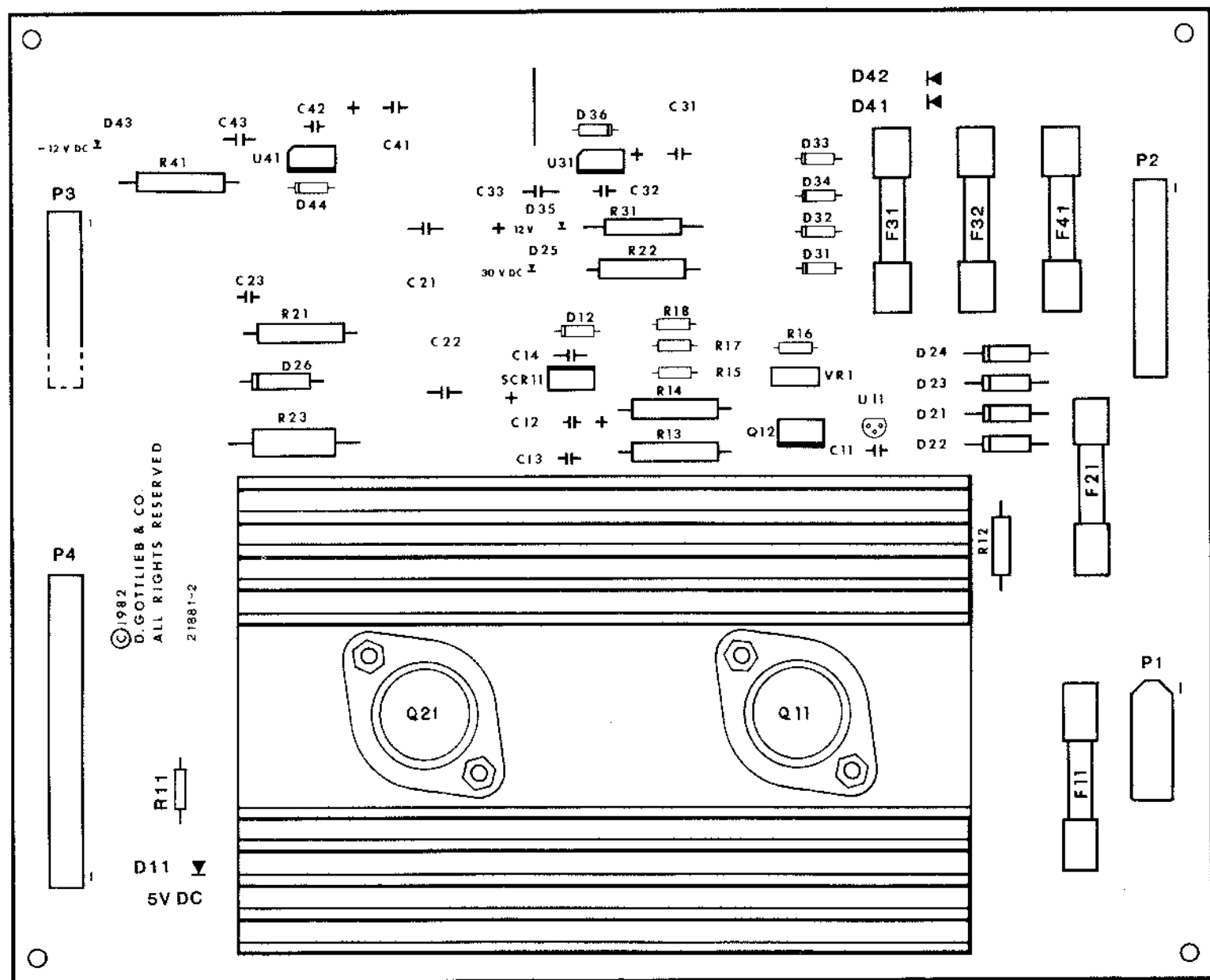

POWER SUPPLY ASSY. (A3), PARTS LIST

REFERENCE	DESCRIPTION	PART NO.	REFERENCE	DESCRIPTION	PART NO.
C11, C32, C42	Capacitor, .01 mfd., 50V	MA-430	P2	Connector, 10 PIN	XO-531
C12	Capacitor, 100UF, 16V	XO-229	P3	Connector, 7 PIN	XO-526
C13, C23	Capacitor, 0.1UF, 100V	XO-235	P4	Connector, 16 PIN	XO-372
C14, C33, C43	Capacitor, 0.2UF, 16V	XO-234	Q11	Transistor, PNP, 2N5879	XO-323
C21, C22	Capacitor, 2200UF, 75V	XO-205	Q12	Transistor, NPN, TIP31B	XO-641
C31, C41	Capacitor, 470UF, 35V	XO-132	Q21	Transistor, NPN, 2N3055	XO-301
D11, D25	Diode, Light Emitting MV5752	XO-270	R11	Resistor, 470 OHM, 5% 1/2W	XO-55
D35, D43	Diode, Zener, 5.6V, 5%, 1W, IN4734A	XO-255	R12	Resistor, 100 OHM, 5% 1W	XO-137
D12	Diode, Zener, 5.6V, 5%, 1W, IN4734A	XO-255	R13, R14	Resistor, 12 OHM, 5% 2W	XO-138
D21-D24	Diode, 1N5401	XO-263	R15	Resistor, 200 OHM, 5% 1/4W	XO-43
D26	Diode, Zener, 30V, 5%, 5W, 1N5363B	XO-273	R16	Resistor, 180 OHM, 5% 1/4W	XO-24
D31-D34, D36	Diode, 1N4004	XO-254	R17	Resistor, 100 OHM, 5% 1/4W	XO-28
D41, D42, D44	Diode, 1N4004	XO-254	R18	Resistor, 20 OHM, 5% 1/4W	XO-29
F11	Fuse, 6/4 AMP SLO-BLO	EL-8	R21, R22	Resistor, 1.8KOHM, 5% 2W	XO-135
F21	Fuse, 2 AMP SLO-BLO	EL-7	R23	Resistor, 200 OHM, 5% 5W	XO-133
F31, F32	Fuse, 1/4 AMP SLO-BLO	EL-5	R31, R41	Resistor, 750 OHM, 5% 1W	XO-136
F41	Fuse, 1 AMP SLO-BLO	EL-6	SCR11	Silicon Controlled Rectifier	XO-131
P1	Connector, 4 PIN	PS-87	U11	Diode, Programmable Zener TL431	XO-272
			U31	Voltage Regulator +12V, LM 340T	XO-473
			U41	Voltage Regulator -12V, LM 320	XO-130
			VR1	Potentiometer, 100 OHM	XO-134

X. WIRING AND SCHEMATIC DIAGRAMS, PARTS LISTS

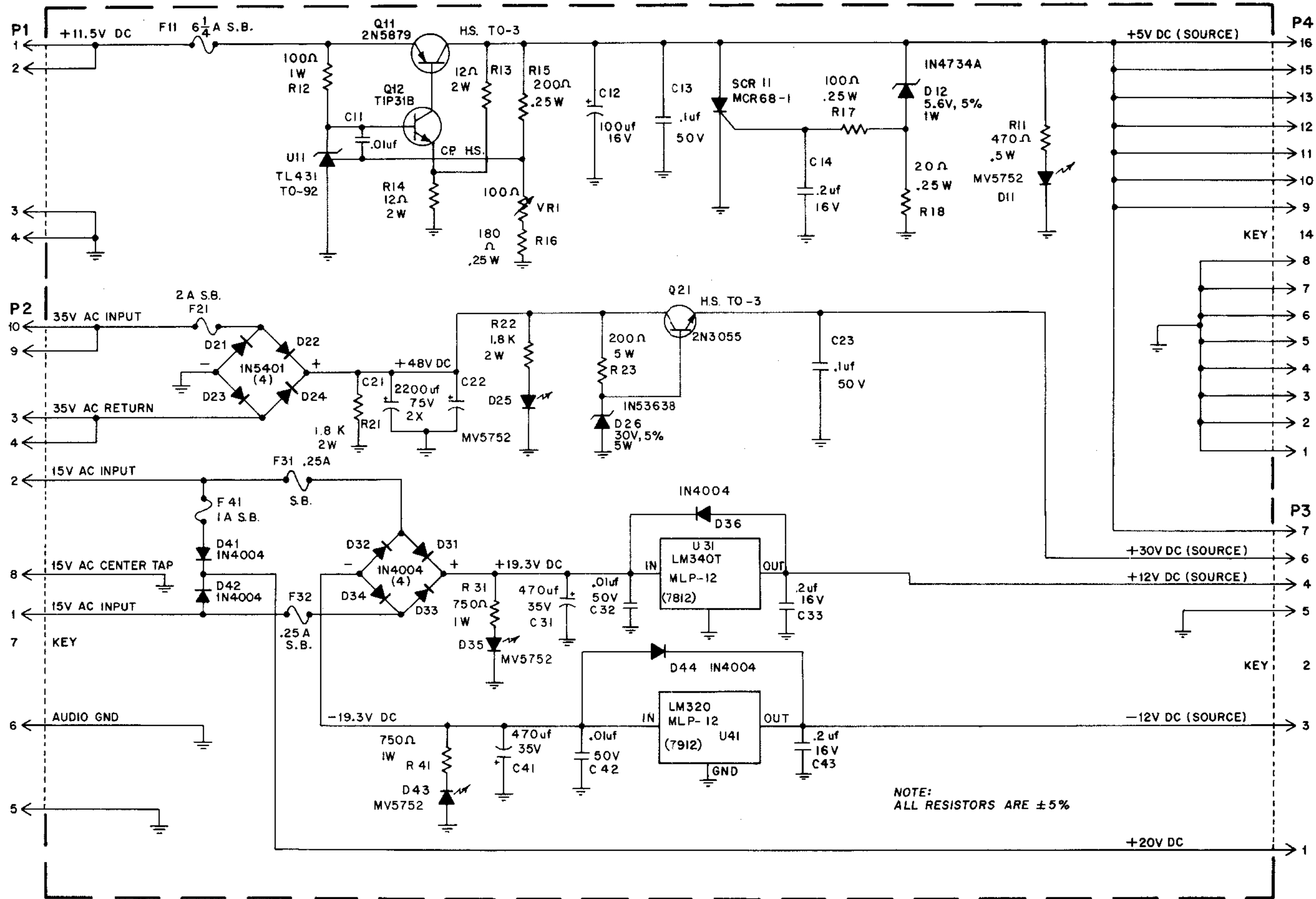

NOTE:
ALL RESISTORS ARE ±5%

POWER SUPPLY ASSY. (A3), SCHEMATIC DIAGRAM

X. WIRING AND SCHEMATIC DIAGRAMS, PARTS LISTS

X. WIRING AND SCHEMATIC DIAGRAMS, PARTS LISTS

SOUND/SPEECH ASSY. (A6), COMPONENT LOCATION

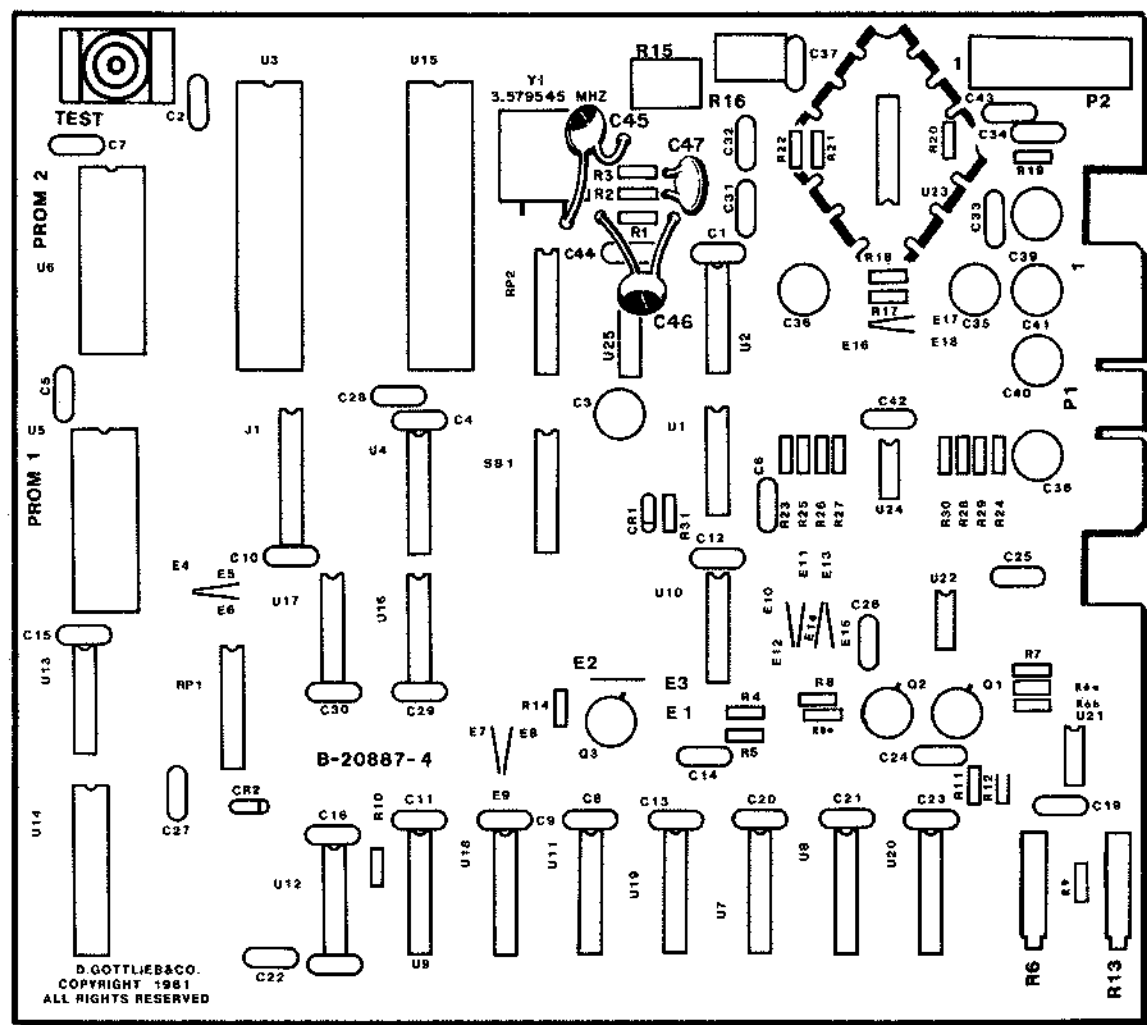

SOUND/SPEECH ASSY. (A6), PARTS LIST

REFERENCE	DESCRIPTION	PART NUMBER	REFERENCE	DESCRIPTION	PART NUMBER
C1, C2	Sound/Speech Assembly Capacitor, 0.1UF, 25V	MA-216	R15, R16	Potentiometer, 10K ohm	XO-109
C4, C13		XO-248	R18, R21	Resistor, 100K ohm, 5%, 1/4W	XO-45
C15, C16, C19			R22	Resistor, 2K ohm, 5%, 1/4W	XO-14
C20, C21, C23			R31	Resistor, 68K ohm, 5%, 1/4W	XO-189
C25, C26			RP1, RP2	Resistor, Dip	XO-168
C28-C30, C33			SB1	Switch, Dip	XO-505
C42, C44			SW1	Switch, Momentary Pushbutton	XO-515
C31-C32	Capacitor, .047UF, 25V	XO-222	U1	IC, 7414	XO-397
C37	Capacitor, 4.7UF, 35V	XO-291	U2	IC, SN74LS74N	XO-434
C3, C38-C41	Capacitor, 4.7UF, 50V	XO-210	U3	CPU, R6502-13	XO-360
C14, C24	Capacitor, 100PF	XO-223	U4	IC, SN74LS138N	XO-437
C22	Capacitor, 300PF	XO-283	U5, U6	EPROM, 2716	PR-53
C27	Capacitor, .1UF, 50V	XO-217	U7-U9, U11, U18	IC, SN74LS75	XO-394
C36	Capacitor, 470UF, 35V	XO-284	U10	IC, SN74LS02N	XO-428
C45, C46	Capacitor, 33PF	XO-277	U12	IC, SN7407N	XO-384
C47	Capacitor, .01UF, 100V	XO-202	U13	IC, Inverter, SN74LS05N	XO-411
CR1	Diode, 1N4148	XO-261	U14	Voice Chip, SC01	XO468
CR2	Diode, Zener, 1N5225B	XO-269	U15	RRIO7, R6532-18	XO-361
Q1, Q3	Transistor, NPN, 2N2222A	XO-320	U16	IC, SN74LS04N	XO-418
Q2	Transistor, PNP, 2N2907A	XO-321	U17	IC, SN74LS30N	XO-432
R1, R4, R5	Resistor, 5.6K ohm, 5%, 1/4W	XO-19	U19, 20	Converter, PMI, 140BA-6P	XO-416
R11, R12			U21, U22	IC, LM741 ICP	XO-393
R2, R3	Resistor, 2K ohm, 5%, 1/4W	XO-14	U23	IC, LM3795	XO-395
R6, R13	Potentiometer, 10K	XO-108	U24	IC, Dual Comparator, LM193	XO-396
R6A, R7, R23-R30	Resistor, 10K ohm, 5%, 1/4W	XO-18	U25	Inverter, 7404	XO-402
R8, RBA, R14	Resistor, 1K ohm, 5%, 1/4W	XO-5	Y1	Crystal, 3.579545MHZ	XO-456
R6B	Resistor, 1.8K ohm, 5%, 1/4W	XO-37		Socket 22 Pin Dip	XO-467
R9	Resistor, 2.2K ohm, 5%, 1/4W	XO-27		Socket 24 Pin [2]	XO-529
R10	Resistor, 1.5K ohm, 5%, 1/4W	XO-20		Socket 40 Pin [2]	XO-530

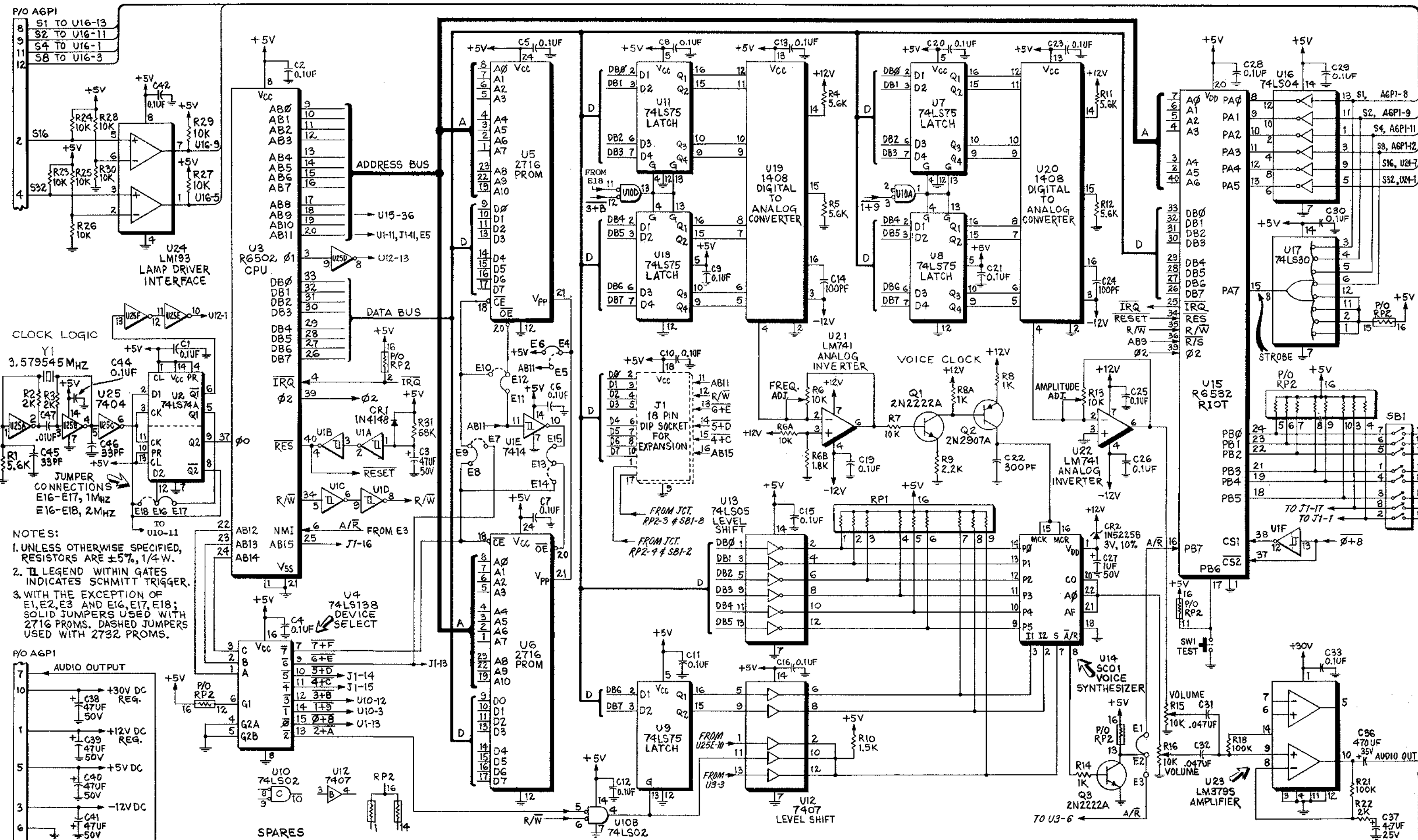

NOTES:
 1. UNLESS OTHERWISE SPECIFIED, RESISTORS ARE ±5%, 1/4-W.
 2. LEGEND WITHIN GATES INDICATES SCHMITT TRIGGER.
 3. WITH THE EXCEPTION OF E1, E2, E3 AND E16, E17, E18; SOLID JUMPERS USED WITH 2716 PROMS. DASHED JUMPERS USED WITH 2732 PROMS.

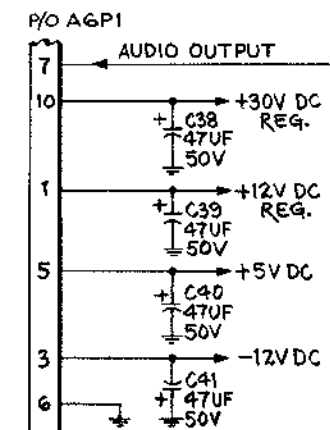

SOUND/SPEECH ASSY. (A6), SCHEMATIC DIAGRAM

X. WIRING AND SCHEMATIC DIAGRAMS, PARTS LISTS

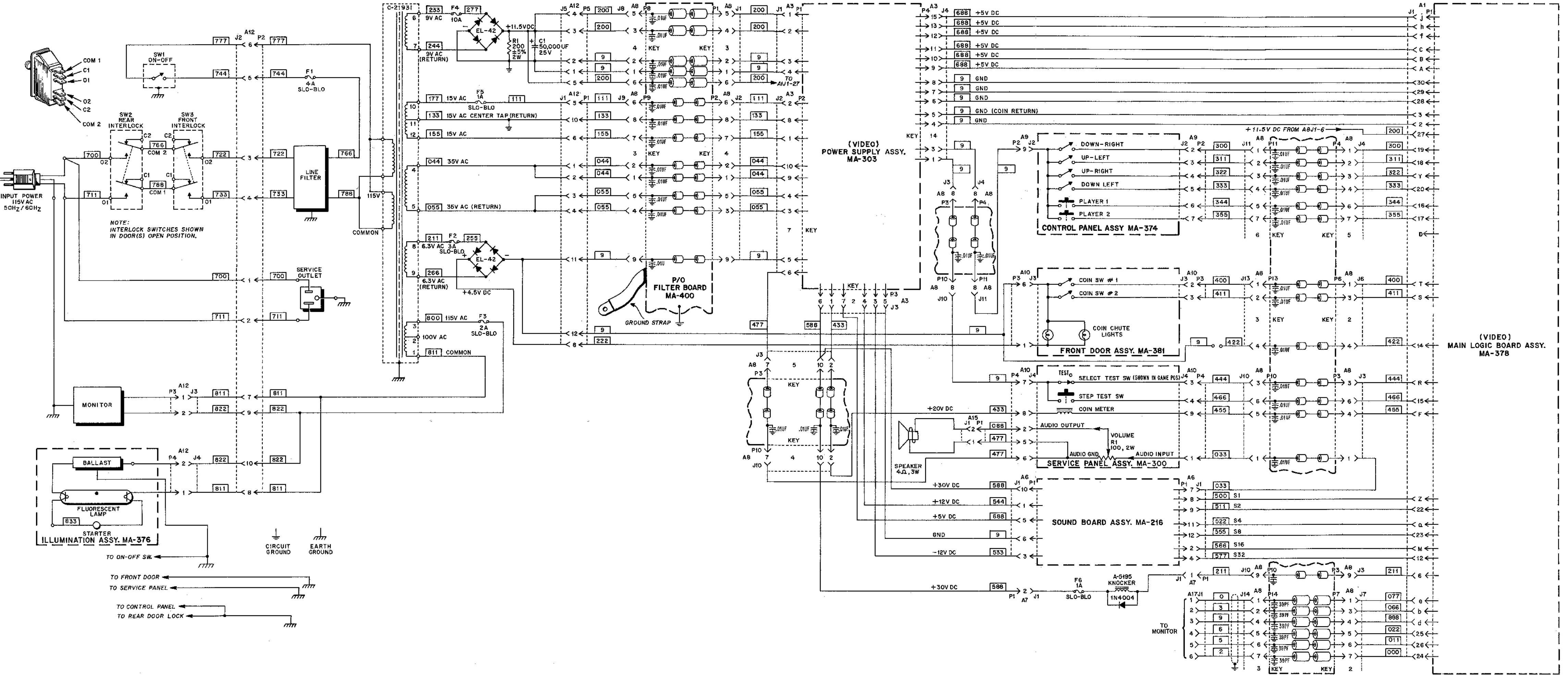

PRIMARY POWER/FILTER BOARD/INTERCONNECTION DIAGRAM

XI. PARTS INFORMATION

TABLE OF CONTENTS

	PAGE
SPEAKER/MARQUEE ASSY.	34
ILLUMINATION ASSY.	34
CONTROL PANEL ASSY.	35
SERVICE PANEL ASSY.....	36
BOTTOM PANEL ASSY.	37
CABINET PARTS	38
CABINET PARTS	39

XI. PARTS INFORMATION

SPEAKER/MARQUEE ASSY. AND ILLUMINATION ASSY.

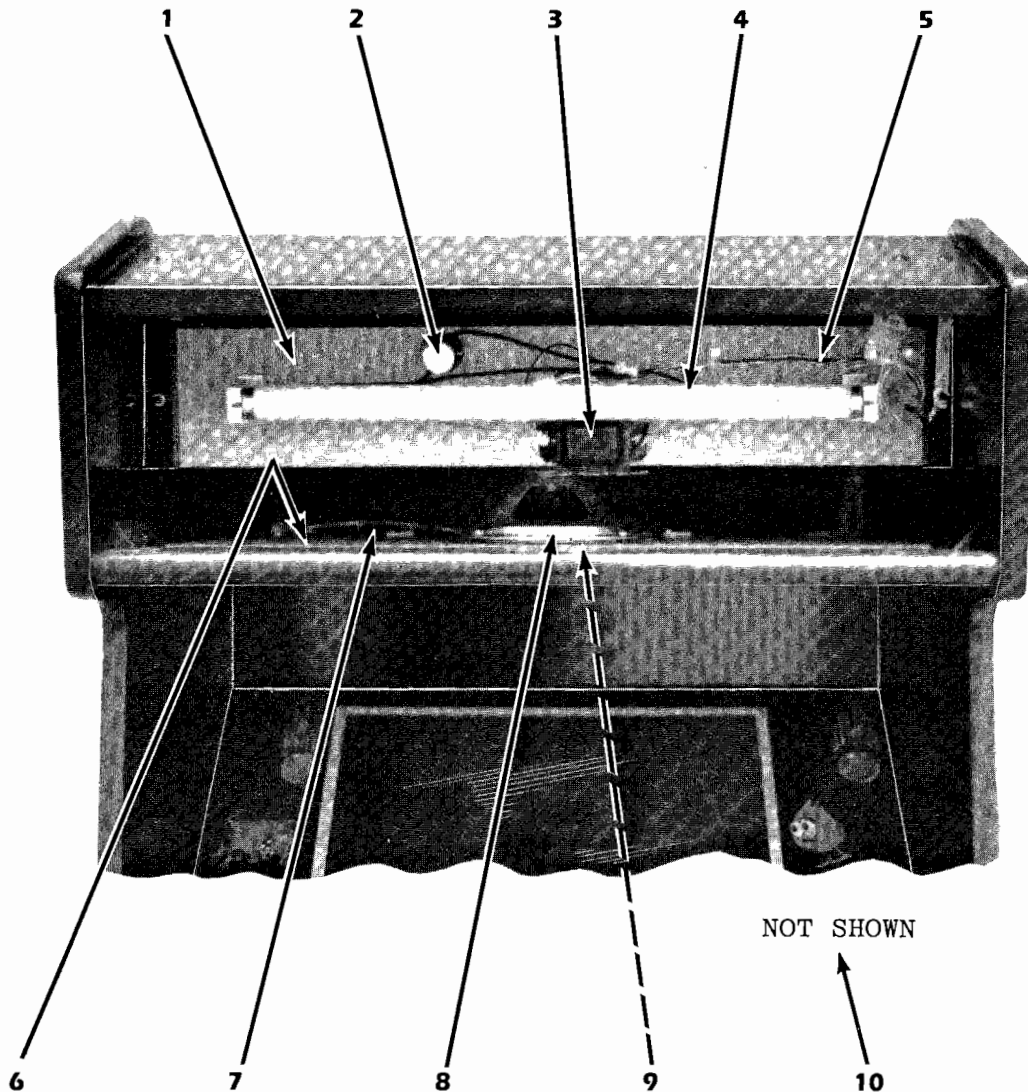

ITEM	DESCRIPTION	PART NO.
1.	Illumination Assy.	MA-376
2.	Starter	EL-69
3.	Ballast (60 HZ)	EL-70
4.	Lamp, Fluorescent	LA-4
5.	Cable Assy.	MA-364
6.	Speaker Assy.	MA-377
7.	Cable Assy.	MA-318
8.	Speaker	EL-83
9.	Speaker Grill	B-20931
10.	Marquee, Lexan (Screen)	DE-3

XI. PARTS INFORMATION

CONTROL PANEL ASSY.

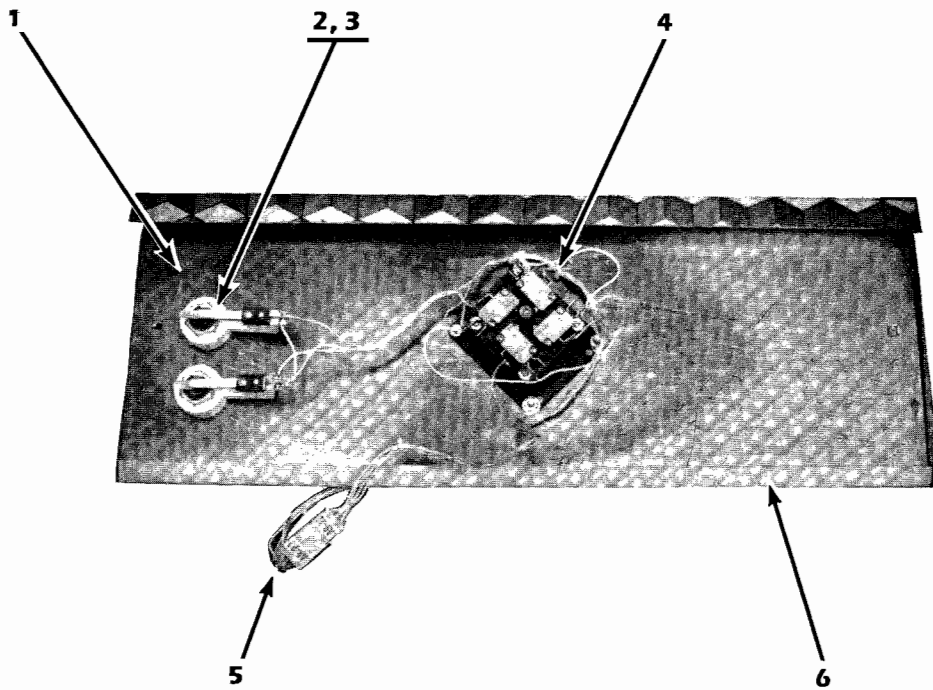

ITEM	DESCRIPTION	PART NO.
1.	Control Panel Assy.	MA-374
2.	Short Button (2)	A-21970
3.	Button Holder and Switch (2)	A-21971
4.	Joystick	C-22458
5.	Cable Assy.	MA-382
6.	Lexan Overlay	DE-1

XI. PARTS INFORMATION

SERVICE PANEL ASSY.

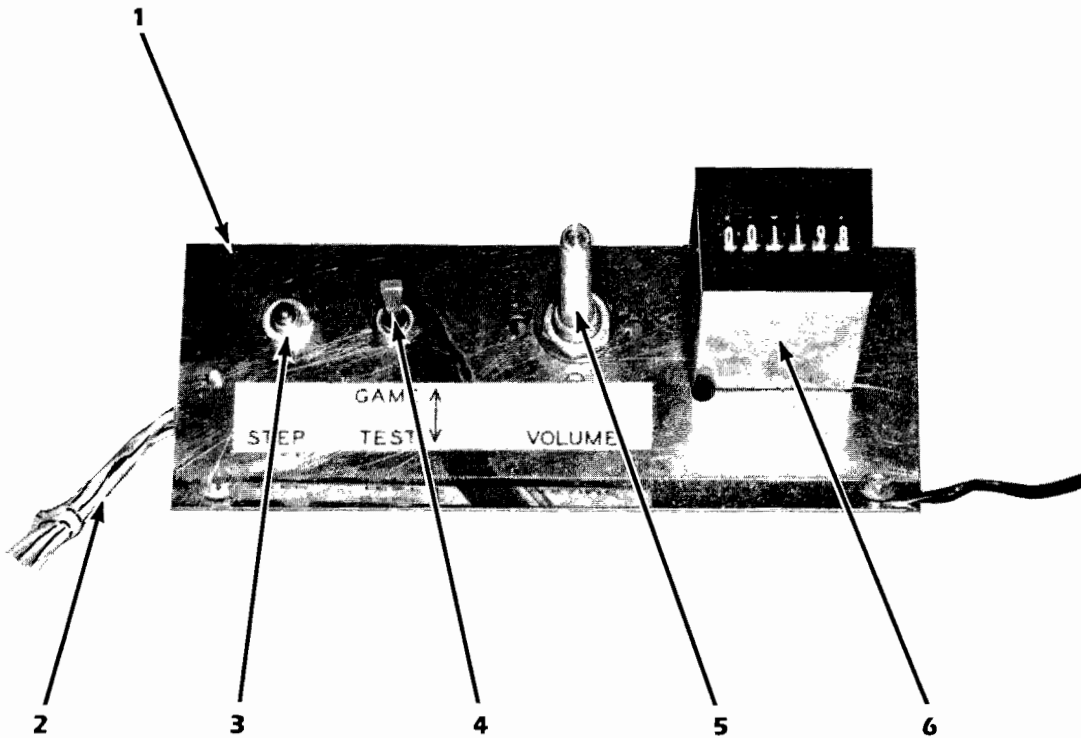

ITEM	DESCRIPTION	PART NO.
1.	Service Panel Assy.	MA-300
2.	Cable Assy.	MA-316
3.	Switch (Push Button)	EL-57
4.	Switch (Toggle)	EL-85
5.	Volume Control	XO-104
6.	Coin Meter	EL-84

XI. PARTS INFORMATION

BOTTOM PANEL ASSY.

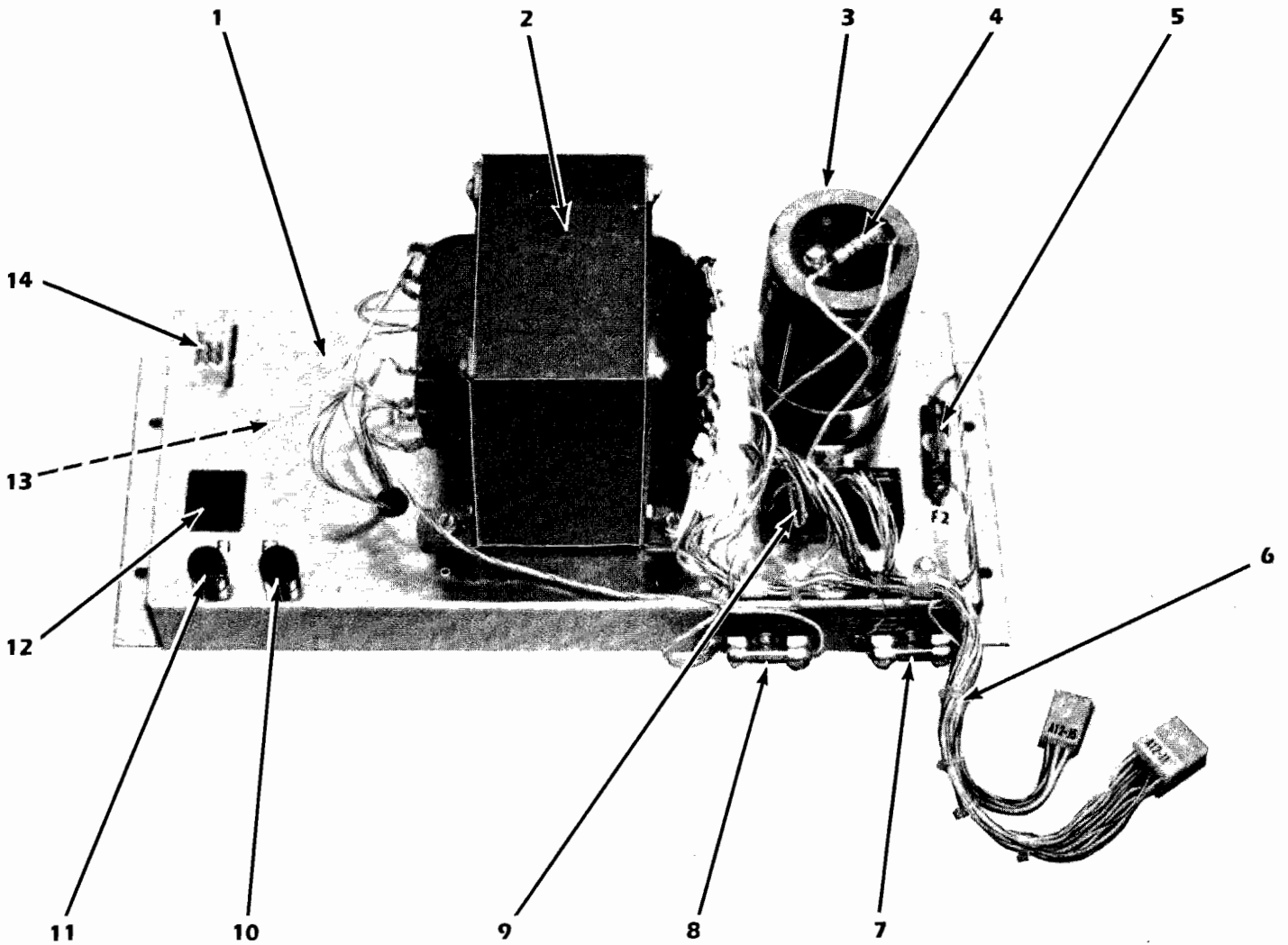

ITEM	DESCRIPTION	PART NO.
1.	Bottom Panel Assy.	MA-375
2.	Transformer	C-21931
3.	Capacitor, 50, 000UF, 25V	XO-141
4.	Resistor, 200 OHM, 5%, 2W	XO-142
5.	Fuse, 3 AMP, SLO-BLO	EL-9
6.	Cable Assy. (Secondary)	MA-314
7.	Fuse, 1 AMP, SLO-BLO	EL-6
8.	Fuse, 10 AMP	EL-23
9.	Bridge Rectifier (2)	EL-42
10.	Fuse, 2 AMP, SLO-BLO	EL-7
11.	Fuse, 4 AMP, SLO-BLO	EL-33
12.	Service Outlet	A-18133
13.	Line Filter	EL-50
14.	Cable Assy. (Primary)	MA-363

CABINET PARTS

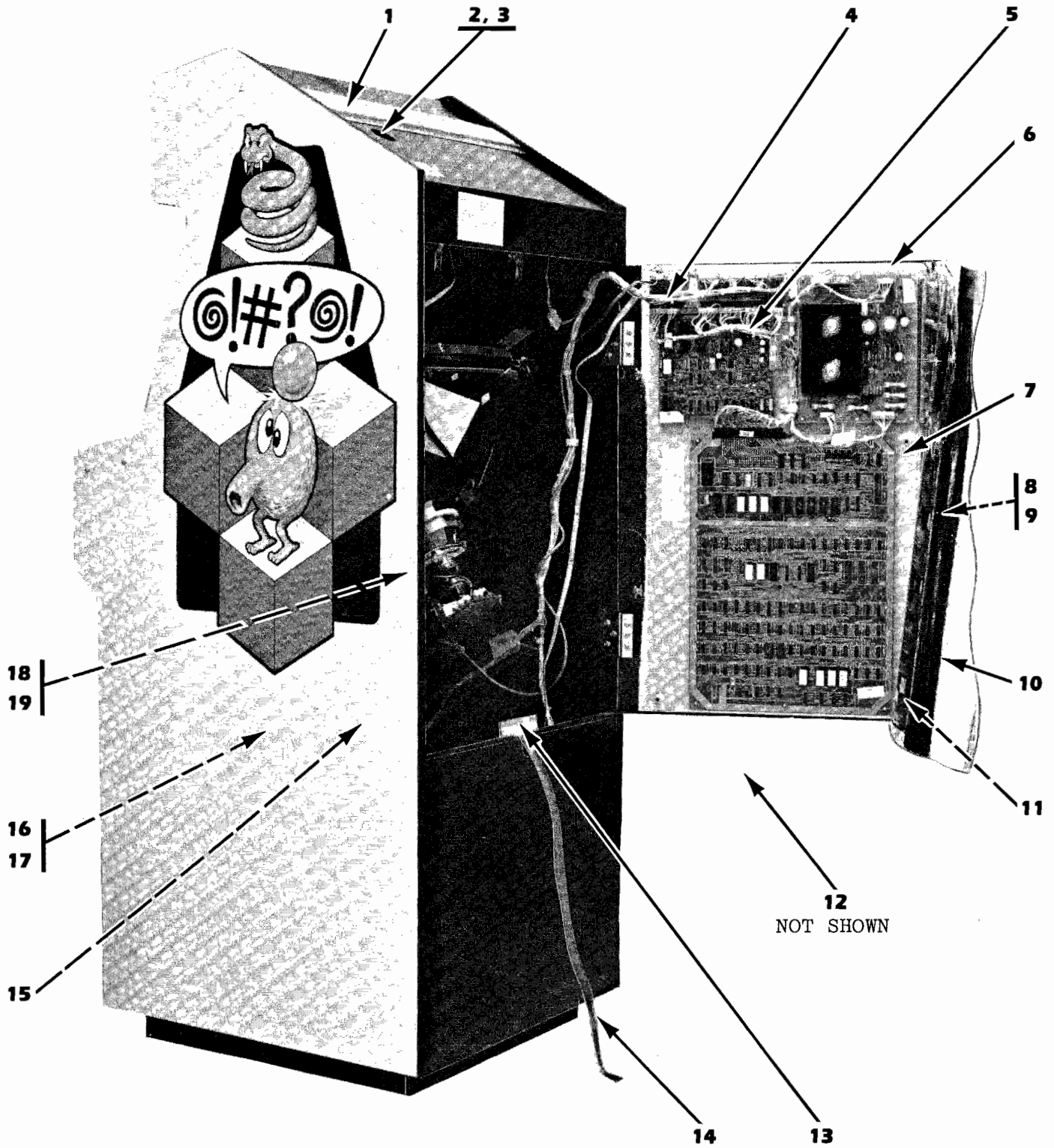

ITEM	DESCRIPTION	PART NO.
1.	Vent Channel (1)	D-21754
2.	On-Off Switch	EL-56
3.	Switch Plate	A-22396
4.	Cable Assy. Master Electronics	MA-397
5.	Interconnect Cable	MA-398
6.	Back Door	D-21896
7.	Master Electronic Board	MA-394
8.	Rear Door Lock	MH-0
9.	Anchor Plate, Lock	MH-1
10.	Shield, Top	C-22632

ITEM	DESCRIPTION	PART NO.
11.	Shield, Bottom	C-22633
12.	Clip Bracket, Shield	B-22631
13.	Line Cord	B-15357
14.	Cover Plate, Line Cord	A-21955
15.	Cable Assy. High Voltage	MA-360
16.	Knocker Assy.	MA-384
17.	Fuse, 1 AMP, SLO-BLO	EL-6
18.	Interlock Switch	EL-66
19.	Cover, Interlock Switch	A-21888

XI. PARTS INFORMATION

CABINET PARTS

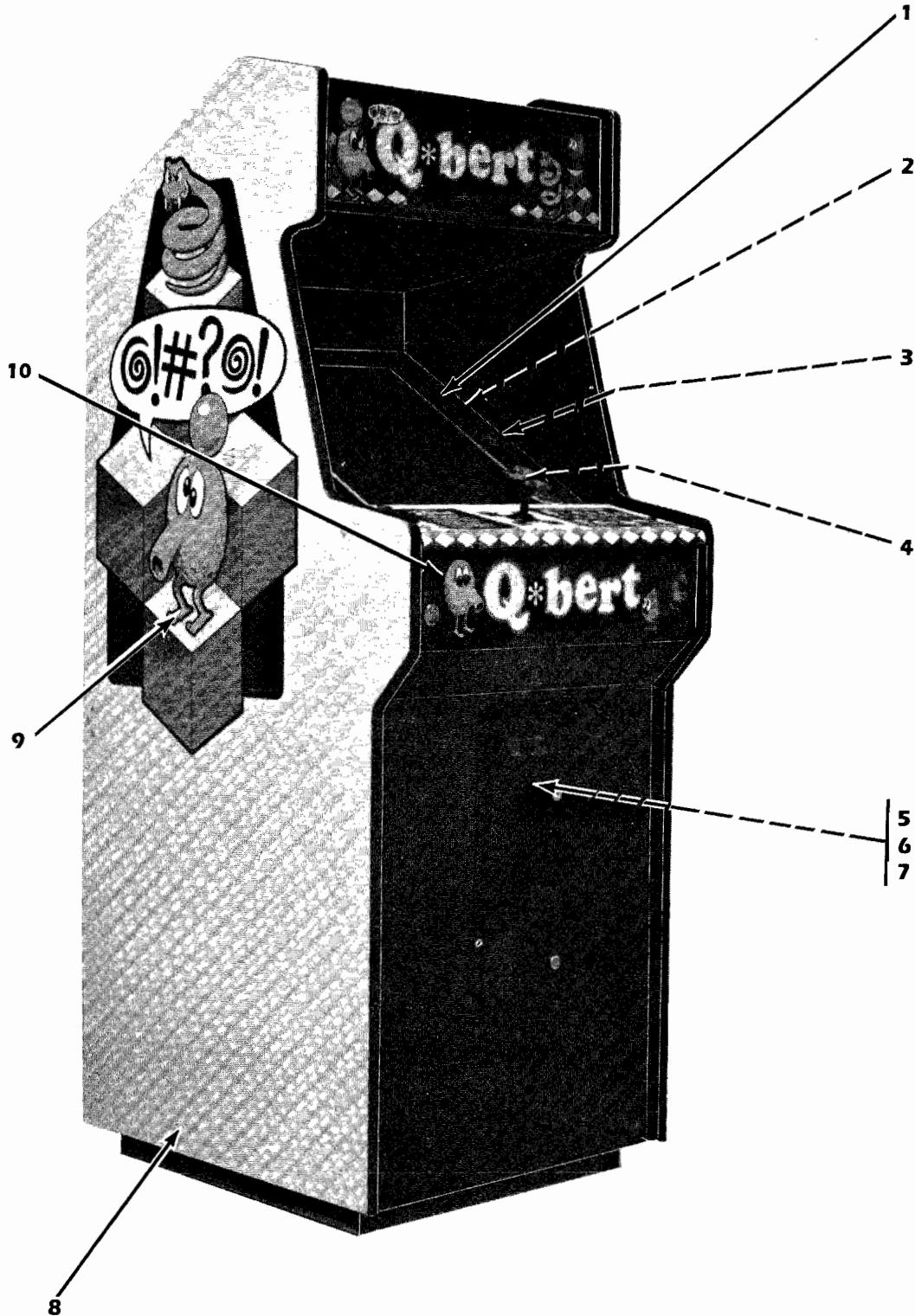

ITEM	DESCRIPTION	PART NO.	ITEM	DESCRIPTION	PART NO.
1.	Top Glass (Screened)	SG-1	7.	Cover, Interlock Switch	A-21888
2.	Monitor Filter Glass	D-22465	8.	3" Leg Adjuster (2)	MH-21
3.	Monitor Mask	D-22463	9.	Decal (Right)	DE-4
4.	Monitor	C-22462		Decal (Left)	DE-4
5.	Cable Assy., Front Door	MA-365	10.	Lexan Overlay (Screen)	DE-2
6.	Interlock Switch	EL-66			

SERVICE NOTES



WELLS-GARDNER ELECTRONICS CORPORATION

19" IN LINE COLOR MONITORS

MODELS

19K4901
19K4906

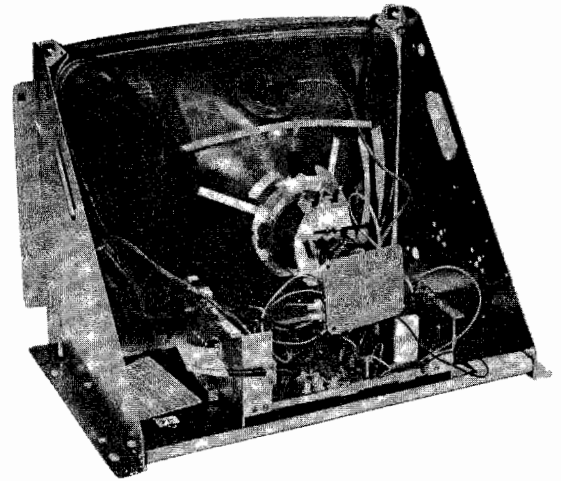
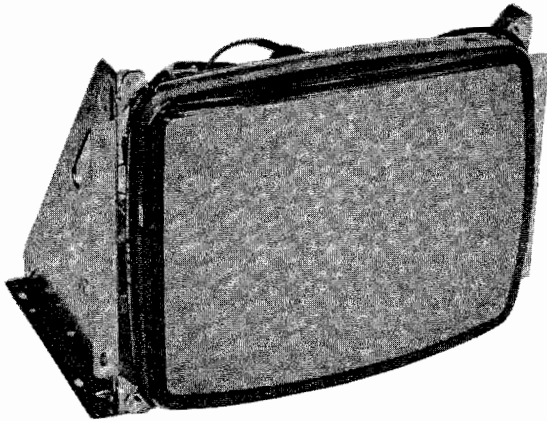

MODELS

19K4951
19K4956

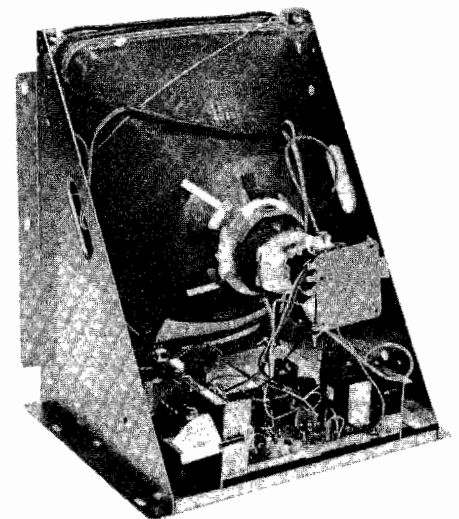
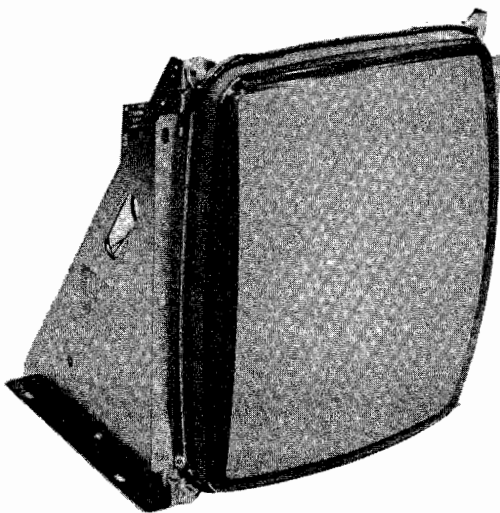

**WELLS-GARDNER ELECTRONICS
CORPORATION**

2701 NORTH KILDARE AVENUE
CHICAGO, ILLINOIS 60639

WARNINGS

1. Power Up Warning—

An isolation transformer must be used between the AC supply and the AC plug of the monitor before servicing or testing is performed since the chassis and the heat sink are directly connected to one side of the AC line which could present a shock hazard.

Before servicing is performed, read all the precautions labelled on the CRT and chassis.

2. **X-RAY RADIATION WARNING NOTICE**

WARNING: PARTS WHICH INFLUENCE X-RAY RADIATION IN HORIZONTAL DEFLECTION, HIGH VOLTAGE CIRCUITS AND PICTURE TUBE ETC. ARE INDICATED BY (★) IN THE PARTS LIST FOR REPLACEMENT PURPOSES. USE ONLY THE TYPE SHOWN IN THE PARTS LIST.

3. High Voltage—

This monitor contains HIGH VOLTAGES derived from power supplies capable of delivering LETHAL quantities of energy. Do not attempt to service until all precautions necessary for working on HIGH VOLTAGE equipment have been observed.

4. CRT Handling—

Care must be taken not to bump or scratch the picture tube as this may cause the picture tube to implode resulting in personal injury. Shatter proof goggles must be worn when handling the CRT. High voltage must be completely discharged before handling. Do not handle the CRT by the neck.

5. **PRODUCT SAFETY NOTICE**

WARNING: FOR CONTINUED SAFETY REPLACE SAFETY CRITICAL COMPONENTS ONLY WITH MANUFACTURER RECOMMENDED PARTS. THESE PARTS ARE IDENTIFIED BY SHADING AND BY (Δ) ON THE SCHEMATIC DIAGRAM.

AVERTISSEMENT: POUR MAINTENIR LE DEGRE DE SECURITE DE L'APPAREIL NE REMPLACER LES COMPOSANTS DONT LE FONCTIONNEMENT EST CRITIQUE POUR LA SECURITE QUE PAR DES PIECES RECOMMANDEES PAR LE FABRICANT.

For replacement purposes, use the same type or specified type of wire and cable, assuring the positioning of the wires is followed (especially for H.V. and power supply circuits). Use of alternative wiring or positioning could result in damage to the monitor or in a shock or fire hazard.

PERFORMANCE AND OPERATING DATA

1. Apply a suitable power source to the monitor through an isolation transformer.
2. Apply a suitable signal source to the monitor PCB by means of P201 and P202
3. Set Up Controls.

All controls are preset at the factory, but may be adjusted to suit program material.

1.0 Supply

Voltage	108 VAC-132 VAC
Frequency	50 Hz-60 Hz

Note: Apply supply voltage through an isolation transformer with 1 Amp. minimum capability.

2.0 High Voltage (EHT)

For 19"V models	24.3 ± 0.8 K.V. at 0 Beam;	22.8 ± 0.8 K.V. at 1 mA Beam
-----------------	----------------------------	------------------------------

Note: Condition for above: A.C. = 120V

3.0 Service Set-Up Controls

MAIN PC BOARD

- 3.1 Vertical Hold Control, VR301
- 3.2 Vertical Size Control, VR303
- 3.3 Horizontal Hold Control, VR351
- 3.4 Vertical Raster Position Adjustment Jumper (3 positions)
- 3.5 Horizontal Raster Position Adjustment Jumper (3 positions)
- 3.6 Screen Control (Part of H.V. Unit, T352)
- 3.7 Focus Control (Part of H.V. Unit, T352)

- 3.8 Horizontal Width Coil, L352
- 3.9 Black Level Control, VR201
- 3.10 Horizontal Video Position Control, (Horizontal Shift) VR352

NECK PC BOARD

- 3.11 Video Drive Controls, Red VR401
Green VR402
- 3.12 CRT Cut Off Controls, Red VR403
Green VR404
Blue VR405

SERVICE INSTRUCTIONS

NOTE: All monitors are equipped with automatic degaussing coils (L701) which demagnetize the picture tube every time the monitor is turned on after being off for a minimum of 5 minutes. Should any part of the chassis become magnetized it will be necessary to degauss the affected area with a manual degaussing coil. Move the coil slowly around the CRT face area and all surrounding metal parts. Then slowly withdraw for a distance of 6 feet before turning off.

1.0 BLACK LEVEL CONTROL ADJUSTMENT

This control has been set at the factory and should not need further attention, however, when the game is connected a slight adjustment of VR201 may be necessary to obtain the proper black level (the black portion of the picture just extinguished).

2.0 VERTICAL SIZE (HEIGHT)

Location of this control is shown in Fig. 1. This control must be adjusted slowly, if necessary, until the picture or test pattern attains the correct vertical proportions.

3.0 CIRCUIT PROTECTION

A 4.0A pigtail fuse, mounted on the Main Board has been provided to protect the Power Output Circuit.

4.0 FOCUS

Adjust the Focus control, located on the HV unit (T352), for maximum over-all definition and fine picture detail.

5.0 HORIZONTAL HOLD CONTROL ADJUSTMENT, VR351 (See Fig. 1)

A warm-up period of at least five minutes should be allowed before alignment is carried out. With the monitor being driven from the game signal, short TP601 to TP31. Adjust VR351 until the picture stops sliding horizontally. Remove the short.

6.0 HORIZONTAL VIDEO POSITION

If the video is off center on the raster some compensation can be made by adjusting this control.

7.0 VERTICAL RASTER POSITION ADJUSTMENT

If the video is off center vertically, (short dimension of picture tube) some compensation can be made by moving the vertical raster position adjustment jumper to either positions "U" or "D".

8.0 HORIZONTAL RASTER POSITION ADJUSTMENT

If the video is off center horizontally (long dimension of the picture tube) some compensation can be made by moving the horizontal raster position adjustment jumper to either positions "R" or "L".

9.0 HORIZONTAL WIDTH ADJUSTMENT

The horizontal width coil is a hexagonal tuning tool adjustment. This control must be adjusted slowly, if necessary, until the picture or test pattern attains the correct horizontal proportions.

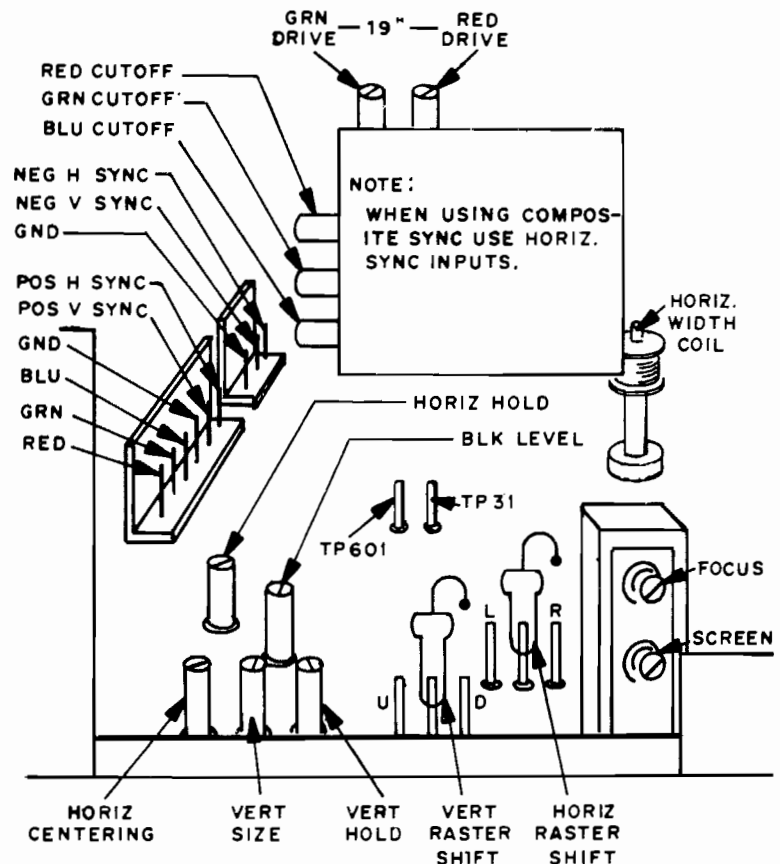

FIGURE 1

INSTALLATION AND SERVICE INSTRUCTIONS

NOTE: All of the following procedures have been performed at the factory and should require no further attention. If the monitor is serviced for any reason, it should be observed afterward to determine whether any of these procedures need to be performed again.

OUTLINE OF CONVERGENCE AND SET-UP PROCEDURE

- 1.0 Degaussing-Demagnetize the shadow mask and all surrounding metal parts with an external degaussing coil.
 - 2.0 Purity and Vertical Centering—Adjust the purity magnet and the yoke position.
 - 3.0 Static Convergence-Converge Red and Blue on Green in the center of the screen.
 - 4.0 Dynamic Convergence-Converge Red and Blue at the edges of the screen.
 - 5.0 White Balance-Set Gray and White brightness tracking.
- NOTE: Number 2.0 and 3.0 adjustments interact.

1.0 DEGAUSSING

The monitor is equipped with an automatic degaussing circuit. However, if the CRT shadow mask has become excessively magnetized, it may be necessary to degauss it with a manual coil. Do not switch the coil OFF while the raster shows any effect from the coil.

2.0 COLOR PURITY AND VERTICAL CENTERING ADJUSTMENT

- 2.1 For best results, it is recommended that the purity adjustment be made in the final monitor location. If the monitor will be moved, perform this adjustment with it facing west or east. The monitor must have been operating 15 minutes prior to this procedure.
- 2.2 Set the converger assembly on the CRT neck with the center line (of the Purity Adjustment Magnet) over the gap between grids no. 3 & 4. (See Figures 2 & 6)
- 2.3 Make certain that the magnetic ring-pairs are in their correct positions before starting procedure. This produces a zero-correction state and helps facilitate adjustments.
- 2.4 Vertical raster position adjustment jumper must be in position "C" (center).
- 2.5 Remove the R-G-B signal from the monitor.
- 2.6 Turn the Green Cut off Control (VR404) on the Neck Board fully CW. (See Fig. 3)
- 2.7 Turn the Red and Blue Cut off Controls (VR403 & VR405) fully CCW.
- 2.8 Pull the Deflection Yoke backward so that the Green belt will appear. (See Fig. 4)
- 2.9 Decrease the horizontal width of the raster, if necessary, in order to be able to see the right and left edges of the raster.
- 2.10 Move the two Purity Magnets with respect to each other in order to center the raster on the screen and the Green belt on the raster horizontally.
- 2.11 Push the Deflection Yoke forward gradually and fix it at the place where the Green screen becomes uniform throughout.
- 2.12 Turn the Cut off and Drive Controls and confirm that each color is uniform.
- 2.13 If the color is not uniform, re-adjust it moving the Purity Magnets slightly.
- 2.14 Decrease the vertical size of the raster, if necessary, such that the top and bottom raster edges can be seen.

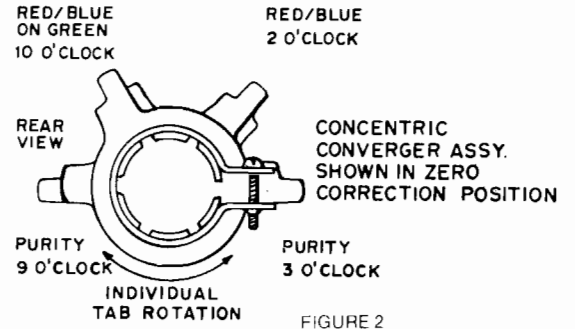
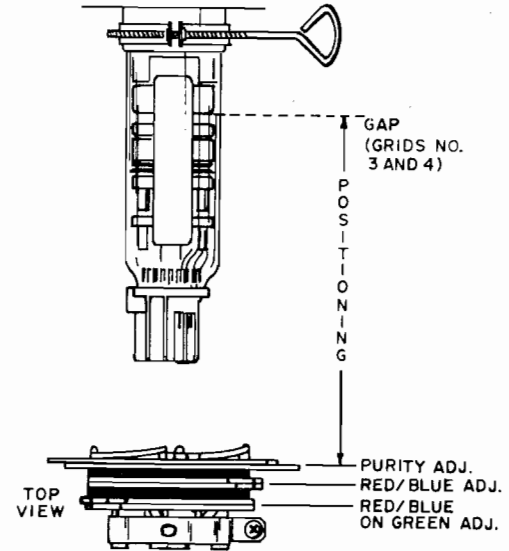

FIGURE 2

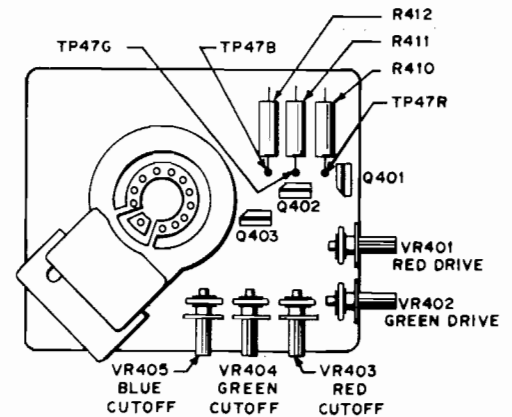

FIGURE 3

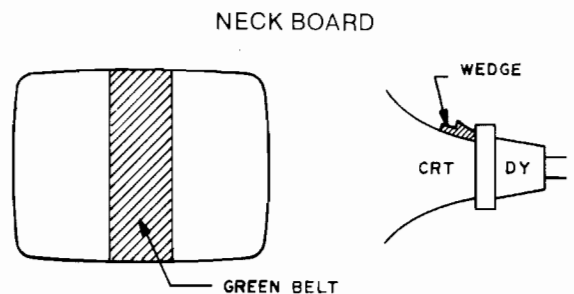

FIGURE 4

- 2.15 Rotate the Purity Magnets as a pair (without changing the angle of one magnet relative to the other) in order to center the raster on the screen vertically.
- 2.16 Readjust the raster to the desired vertical size.
- 2.17 Turn all three cut off controls fully counterclockwise (CCW). Slowly turn up (CW) the Red cutoff control until a Red raster is just barely visible.
- 2.18 Slowly turn up the Green and Blue cutoff controls such that their associated colors, mixing with the Red, results in a White or Gray raster.
- 2.19 Confirm that the white or gray color is uniform throughout the screen.
- 2.20 Insert a wedge temporarily as shown in Fig. 4 and adjust the angle of the Deflection Yoke.

3.0 STATIC CONVERGENCE ADJUSTMENT

4-Pole Magnets and 6-Pole Magnets are for static convergence.

- 3.1 A cross hatch signal should be connected to the monitor.
- 3.2 A pair of 4-Pole Convergence Magnets is provided and adjusted to converge the blue and red beams. (See Fig. 6) When the Pole opens to the left and right 45° symmetrically, the magnetic field maximizes. Red and blue beams move to the left and right. (See Fig. 5) Variation of the angle between the tabs adjusts the convergence of red and blue vertical lines.
- 3.3 When both 4-Pole Convergence Magnet Tabs are rotated as a pair, the convergence of the red and blue horizontal lines is adjusted.
- 3.4 A pair of 6-Pole Convergence Magnets is also provided and adjusted to converge the magenta (red + blue) to green beams. (See Fig. 6). When the Pole opens to the left and right 30° symmetrically, the magnetic field is maximized. Red and blue beams both move to the left and right (See Fig. 5). Variation of the opening angle adjusts the convergence of magenta to green vertical lines.
- 3.5 When both 6-Pole Convergence Magnet Tabs are rotated as a pair, the convergence of magenta to green horizontal lines is adjusted.

GREEN GUN IS THE CENTER GUN.
CONVERGE THE RED AND BLUE.
THEN CONVERGE RED AND BLUE ON GREEN.

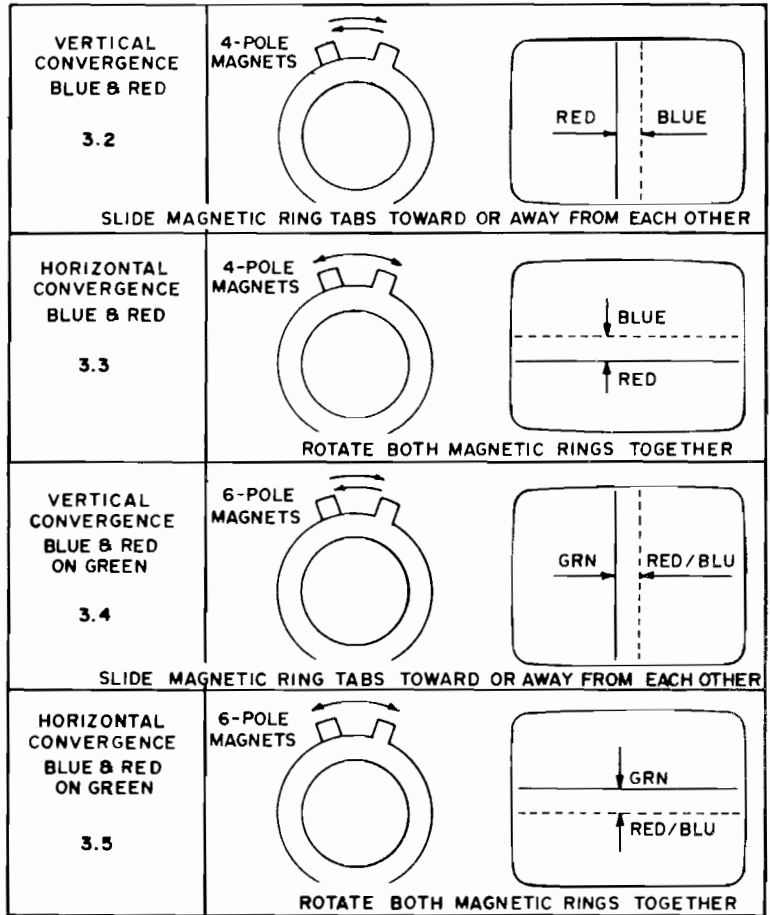

REPEAT 3.2 & 3.3 IF ALL LINES ARE NOT CONVERGED AT CENTER

5827

FIGURE 5

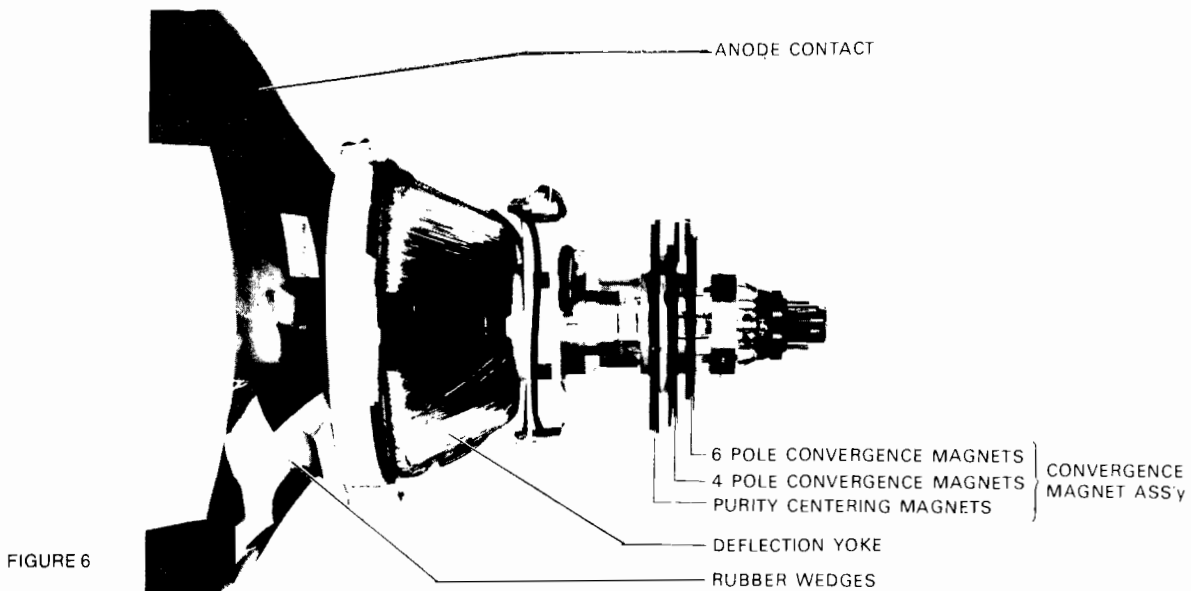

FIGURE 6

4.0 PRECISE ADJUSTMENT OF DYNAMIC CONVERGENCE (See Fig. 7, 8 and 9)

- 4.1 Feed a cross hatch signal to the monitor.
- 4.2 Insert a wedge temporarily and fix the Deflection Yoke so as to obtain the best circumference convergence (See Fig. 8 and 9)

NOTE:

The wedges may need to be moved during adjustments.

- 4.3 Insert three rubber wedges to the position as shown in Fig. 7 to obtain the best circumference convergence.

NOTE:

- 1) Tilting the angle of the yoke up and down adjusts the crossover of both vertical and horizontal red and blue lines. See Fig. 8 (a) and (b).
- 2) Tilting the angle of the yoke sideways adjusts the parallel convergence of both horizontal and vertical lines at the edges of the screen. See Fig. 9 (a) and (b).
- 3) Use three rubber wedges (tapered rubber wedges are used for a purpose).
- 4) The position of each rubber wedge is shown in Fig. 7.
- 5) Do NOT force the permanent wedges in. They are to be inserted until they just make contact with the yoke—after the yoke has been positioned.
- 6) Fix the three permanent rubber wedges with chloroprene rubber adhesive.
- 7) After the adhesive has dried enough to hold the wedges in place, carefully remove the temporarily installed wedge.

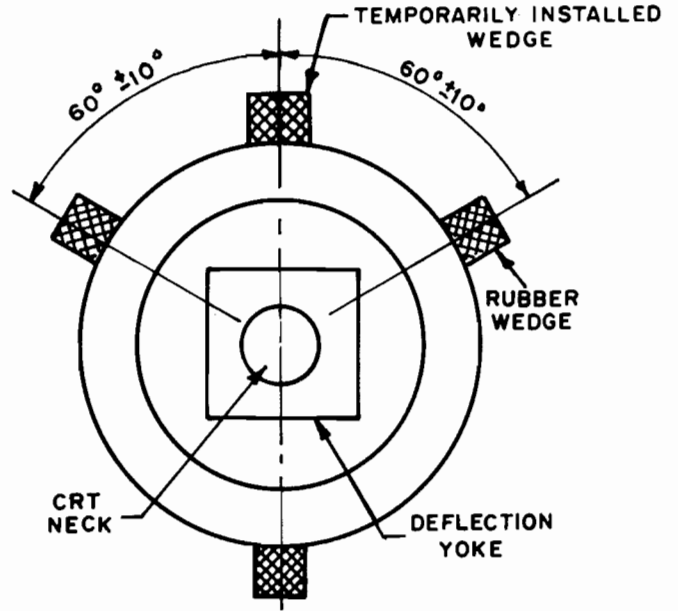
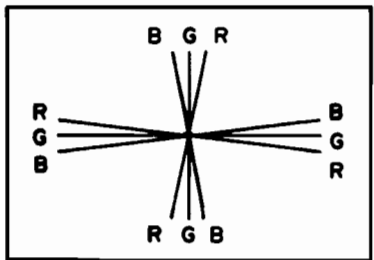
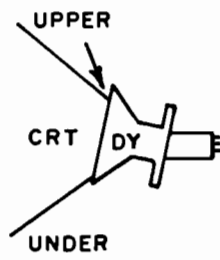

FIGURE 7



CRT SCREEN (a)



INSERT RUBBER WEDGE FROM UPPER SIDE

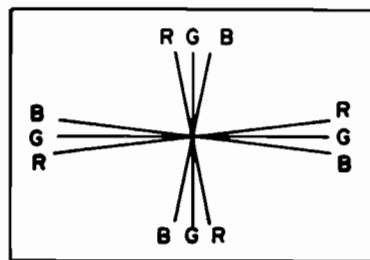

CRT SCREEN (b)

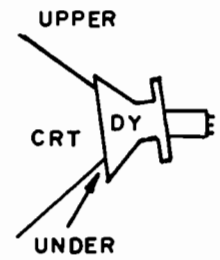

INSERT RUBBER WEDGE FROM LOWER SIDE

FIGURE 8

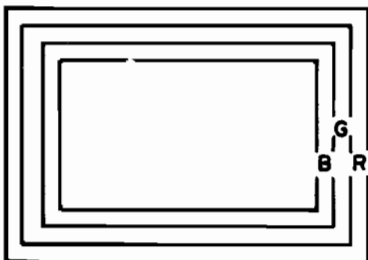

CRT SCREEN (a)

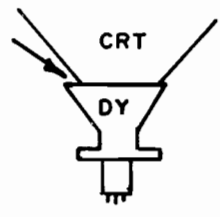

INSERT RUBBER WEDGE FROM LEFT SIDE

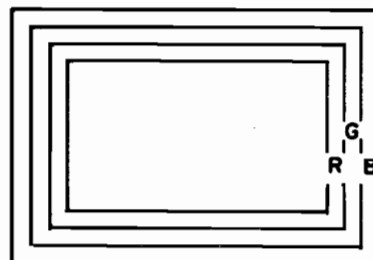

CRT SCREEN (b)

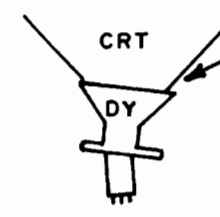

INSERT RUBBER WEDGE FROM LOWER SIDE

FIGURE 9

5.0 WHITE BALANCE

- 5.1 Refer to Fig. 2 and do the following in subdued light.
- 5.2 Ground the R/G/B inputs.
- 5.3 Set the R/G drive controls to their mechanical centers.
- 5.4 Set the screen and R/G/B cutoff controls to minimum (fully CCW).
- 5.5 Connect a jumper wire between TP301 and TP302 (located on the MAIN PCB)
- 5.6 Slowly turn up (CW) the screen control until the first colored line becomes just barely visible. That color which has just appeared is referred to as the "lead" color. Do NOT turn its associated cutoff control—it must remain fully CCW.
- 5.7 Connect a DC oscilloscope to the collector of the lead color's output transistor (Q401, Q402, or Q403) on the Neck PCB at TP47R, TP47G, or TP47B.
- 5.8 Adjust the black level control (VR201) to obtain the waveform shown in Fig. 10.
- 5.9 Readjust the screen control such that the colored line is just barely visible.
- 5.10 Slowly turn up the two remaining cutoff controls such that their associated colors, mixing with the lead color, results in a white or gray line.
- 5.11 Remove the jumper wire.
- 5.12 Adjust the Black Level Control for a dim raster. Touch up the two trailing cutoff controls (NOT the lead cutoff control) for best gray uniformity.
- 5.13 Adjust the Black Level Control for a bright raster. Adjust the R/G drive controls, if necessary for best neutral white.
- 5.14 Repeat steps 5.12 and 5.13 until good tracking of white balance is achieved.

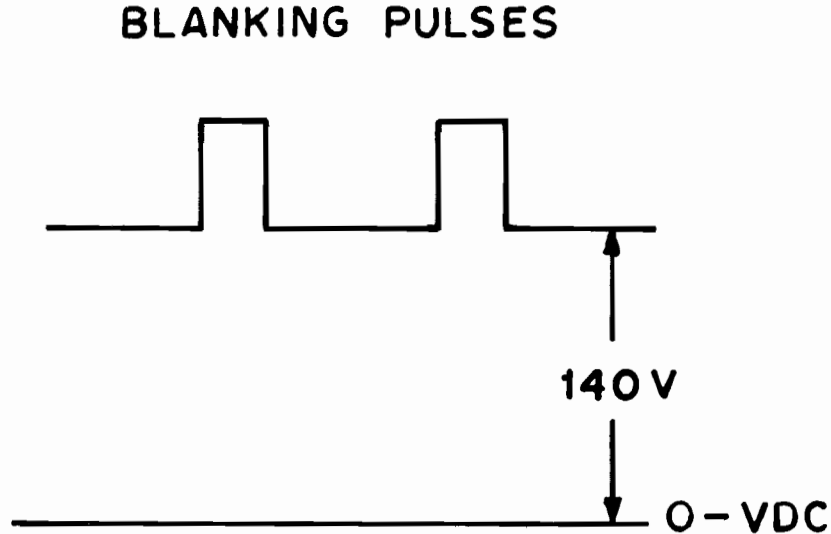

FIGURE 10

REPLACEMENT PARTS LIST

This monitor contains circuits and components included specifically for safety purposes.

For continued protection no changes should be made to the original design, and components shown in shaded areas of schematic, or Δ \star on parts list should be replaced with exact factory replacement parts.

The use of substitute parts may create a shock, fire, radiation or other hazard. Service should be performed by qualified personnel only.

MAIN BOARD

Ref. No.	Part No.	Description	Ref. No.	Part No.	Description
RESISTORS			RESISTORS (CONT.)		
R201	203X6500-645	1K Ohm, 5%, 1/4W Carbon	R369	203X5602-329	680K Ohm, 5%, 1/2W Comp.
R202	203X6500-523	30 Ohm, 5%, 1/4W Carbon	R370	203X6501-002	33K Ohm, 5%, 1/4W Carbon
R203	203X6500-405	100 Ohm, 5%, 1/4W Carbon	R371	203X9014-584	1K Ohm, 5%, 1W Metal Oxide
R204	203X6700-327	100 Ohm, 5%, 1/2W Carbon	R372	203X9101-119	12K Ohm, 5%, 1W Metal Oxide
R205	203X6700-421	270 Ohm, 5%, 1/2W Carbon	R375	203X6700-763	6.8K Ohm, 5%, 1/2W Carbon
R206	203X6500-540	390 Ohm, 5%, 1/4W Carbon	R376	203X9104-404	270 Ohm, 5%, 2W Metal Oxide
R207	340X2201-934	200 Ohm, 5%, 1/4W Carbon	R377	203X6500-447	150 Ohm, 5%, 1/4W Carbon
R208	203X6500-540	390 Ohm, 5%, 1/4W Carbon	R378	203X6500-886	10K Ohm, 5%, 1/4W Carbon
R209	340X2201-934	200 Ohm, 5%, 1/4W Carbon	R379	203X6500-886	10K Ohm, 5%, 1/4W Carbon
R210	203X6500-540	390 Ohm, 5%, 1/4W Carbon	R380	203X6500-865	8.2K Ohm, 5%, 1/4W Carbon
R211	340X2201-934	200 Ohm, 5%, 1/4W Carbon	R381	203X6500-724	2.2K Ohm, 5%, 1W Metal Oxide
R214	203X6500-645	1K Ohm, 5%, 1/4W Carbon	R383	203X9014-387	150 Ohm, 5%, 1W Metal Oxide
R215	203X6501-126	100K Ohm, 5%, 1/4W Carbon	R502	203X6500-886	10K Ohm, 5%, 1/4W Carbon
R216	203X6500-645	1K Ohm, 5%, 1/4W Carbon	R503	204X1700-535	150 Ohm, 5%, 15W Metal Oxide
R217	203X6500-405	100 Ohm, 5%, 1/4W Carbon	R504	203X9014-267	47 Ohm, 5%, 1W Metal Oxide
R218	203X6500-645	1K Ohm, 5%, 1/4W Carbon	R505	203X6501-209	2.2K Ohm, 5%, 1/4W Carbon
R219	203X6501-126	100K Ohm, 5%, 1/4W Carbon	R506	203X9104-105	15 Ohm, 5%, 2W Metal Oxide
R220	203X6500-645	1K Ohm, 5%, 1/4W Carbon	R507	203X5602-185	330K Ohm, 5%, 1/2W Comp.
R221	203X6500-405	100 Ohm, 5%, 1/4W Carbon	Δ \star R601	204X1625-058	3.3 Ohm, 5%, 10W WW
R222	203X6500-762	3.3 Ohm, 5%, 1/4W Carbon	R701	203X9105-141	2.2 Ohm, 5%, 2W Metal Oxide
R224	203X6500-169	10 Ohm, 5%, 1/4W Carbon	R702	203X6206-441	2.2 Ohm, 5%, 1/2W Carbon
R225	203X6500-169	10 Ohm, 5%, 1/4W Carbon	VR201	204X2070-072	2K Ohm-B Semi-Fixed
R226	203X6500-169	10 Ohm, 5%, 1/4W Carbon	VR301	204X2070-084	5K Ohm-B Semi-Fixed
R227	203X6501-044	47K Ohm, 5%, 1/4W Carbon	VR303	204X2070-055	500 Ohm-B Semi-Fixed
R228	203X6500-645	1K Ohm, 5%, 1/4W Carbon	VR351	204X2070-072	2K Ohm-B Semi-Fixed
R229	203X6700-421	270 Ohm, 5%, 1/2W Carbon	VR352	204X2070-072	2K Ohm-B Semi-Fixed
R230	203X6500-863	8.2K Ohm, 5%, 1/2W Comp.			
R231	203X6500-863	8.2K Ohm, 5%, 1/2W Comp.			
R232	203X6500-863	8.2K Ohm, 5%, 1/2W Comp.			
R233	203X6500-468	180 Ohm, 5%, 1/4W Carbon			
R234	340X2820-934	82 Ohm, 5%, 1/4W Carbon			
R235	340X2820-934	82 Ohm, 5%, 1/4W Carbon			
R236	340X2820-934	82 Ohm, 5%, 1/4W Carbon			
R301	203X6500-508	270 Ohm, 5%, 1/4W Carbon			
R302	203X6500-863	8.2K Ohm, 5%, 1/4W Carbon	C201	203X0014-088	1000 uF, 16V, Electrolytic
R303	203X6500-863	8.2K Ohm, 5%, 1/4W Carbon	C202	202X7200-064	330 pF, 500V, Ceramic
R304	203X6500-724	2.2K Ohm, 5%, 1/4W Carbon	C203	202X7200-043	220 pF, 500V, Ceramic
R305	203X6500-842	6.8K Ohm, 5%, 1/4W Carbon	C204	202X7200-043	220 pF, 500V, Ceramic
R306	203X6003-201	7.5K Ohm, 2%, 1/4W Carbon	C205	203X0014-076	470 uF, 16V, Electrolytic
R307	203X6500-825	5.6K Ohm, 5%, 1/4W Carbon	C206	203X1810-149	0.1 uF, 125V Mylar
R309	203X6500-965	22K Ohm, 5%, 1/4W Carbon	C207	349X2232-109	.022 uF, 100V Mylar
R310	203X6500-988	39K Ohm, 5%, 1/4W Carbon	C301	203X0014-065	330 uF, 50V Electrolytic
R311	203X6500-762	3.3K Ohm, 5%, 1/4W Carbon	C302	203X1600-563	0.033 uF, 50V Mylar
R312	203X9014-741	4.7K Ohm, 5%, 1/4W Carbon	C303	203X0629-037	3.3 uF, 50V Electrolytic
R313	204X1450-537	1K Ohm, 5%, 5W Carbon	C304	203X1600-366	0.068 pF, 50V Mylar
R314	203X6500-481	220 Ohm, 5%, 1/4W Carbon	C306	203X0412-012	2.2 uF, 16V Tantal
R315	203X6500-169	10 Ohm, 5%, 1/4W Carbon	C307	203X1600-634	0.033 uF, 50V Mylar
R316	203X6500-762	3.3K Ohm, 5%, 1/4W Carbon	C308	203X0025-174	3.3 uF, 50V Electrolytic
R317	203X6700-107	12 Ohm, 5%, 1/2W Carbon	C309	203X1207-100	0.068 uF, 100V PP
R318	203X6500-540	390 Ohm, 5%, 1/4W Carbon	C310	203X0629-061	10 uF, 100V Electrolytic
R319	203X6500-645	1K Ohm, 5%, 1/4W Carbon	C311	203X0041-025	10 uF, 160V Electrolytic
R320	203X6501-002	33K Ohm, 5%, 1/4W Carbon	C312	202X7050-248	1000 pF, 500V Ceramic
R321	203X6501-224	270K Ohm, 5%, 1/2W Carbon	C313	203X0040-052	47 uF, 160V Electrolytic
R322	203X6500-886	10K Ohm, 5%, 1/4W Carbon	C314	203X1201-265	0.033 pF, 200V PP
R351	203X6500-886	10K Ohm, 5%, 1/4W Carbon	C315	203X0629-023	1 uF, 50V Electrolytic
R352	203X6500-785	3.9K Ohm, 5%, 1/4W Carbon	C351	203X0629-023	1 uF, 50V Electrolytic
R353	203X6501-088	68K Ohm, 5%, 1/4W Carbon	C352	203X0619-045	47 uF, 25V Electrolytic
R354	203X6500-762	3.3K Ohm, 5%, 1/4W Carbon	C353	203X1190-015	0.0082 pF, 50V Mylar-PP
R355	203X9205-143	6.8K Ohm, 5%, 3W Metal Oxide	C354	203X0619-045	47 uF, 25V Electrolytic
R358	203X5601-878	56K Ohm, 5%, 1/2W Carbon	C355	203X1600-366	0.0068 pF, 50V Mylar
R360	203X6500-561	470 Ohm, 5%, 1/4W Carbon	C356	202X7050-483	0.01 uF, 500V Ceramic
R361	203X6500-886	10K Ohm, 5%, 1/4W Carbon	C359	202X8065-606	100 pF, 500V Ceramic
R362	203X9014-645	1.8K Ohm, 5%, 1W Metal Oxide	C360	202X7050-366	0.0033 pF, 500V Ceramic
\star R363	204X1527-751	3.9K Ohm, 5%, 7W Metal Oxide	C361	202X7050-483	0.01 uF, 500V Ceramic
R364	203X6500-246	22 Ohm, 5%, 1/4W Carbon	C362	202X7203-032	0.01 uF, 50V Ceramic
R365	203X6501-002	33K Ohm, 5%, 1/4W Carbon	Δ \star C363	203X1270-911	8700 pF, 1.5 KV PP
R367	203X6500-886	10K Ohm, 5%, 1/4W Carbon	\star C365	203X1201-265	0.33 uF, 200V PP
R368	203X5602-185	330K Ohm, 5%, 1/2W Comp.	C366	203X0019-026	22 uF, 25V Electrolytic
			C367	202X8065-162	6 pF, 500V Ceramic
			C368	202X7203-032	0.01 uF, 50V Ceramic
			C372	203X1207-125	0.1 uF, 100V PP

P.C. BOARD LAYOUT

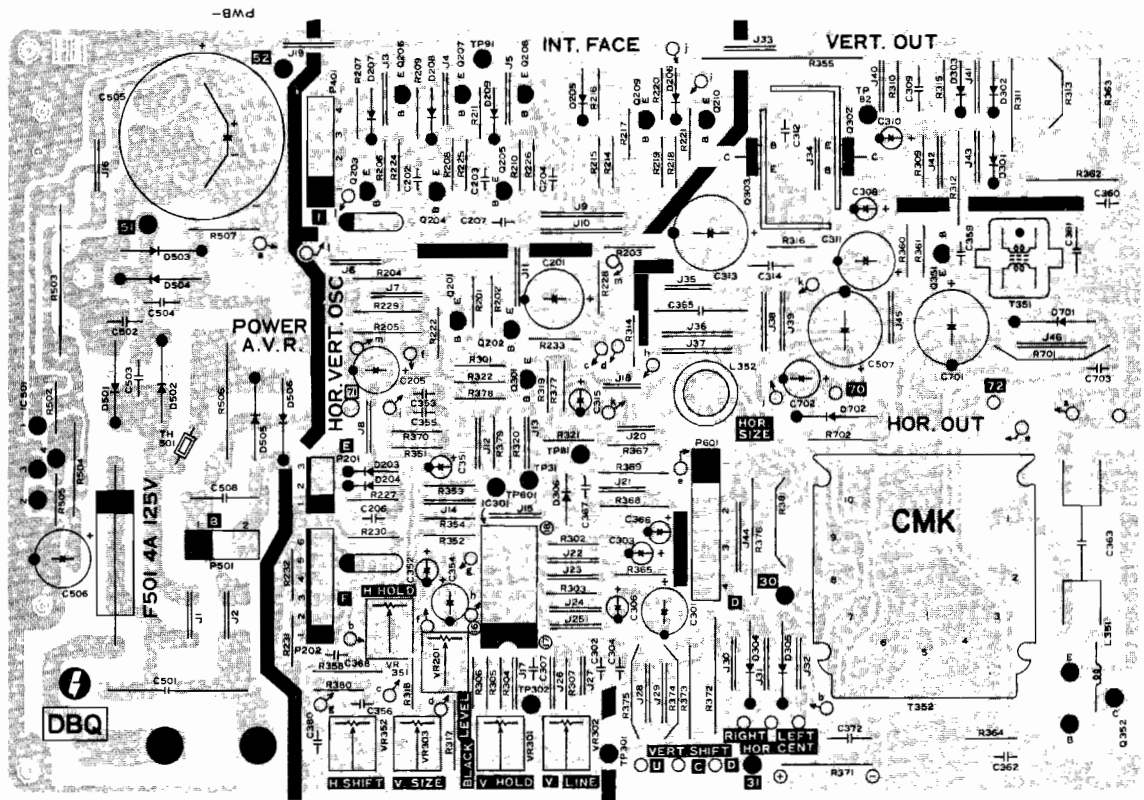

TOP VIEW

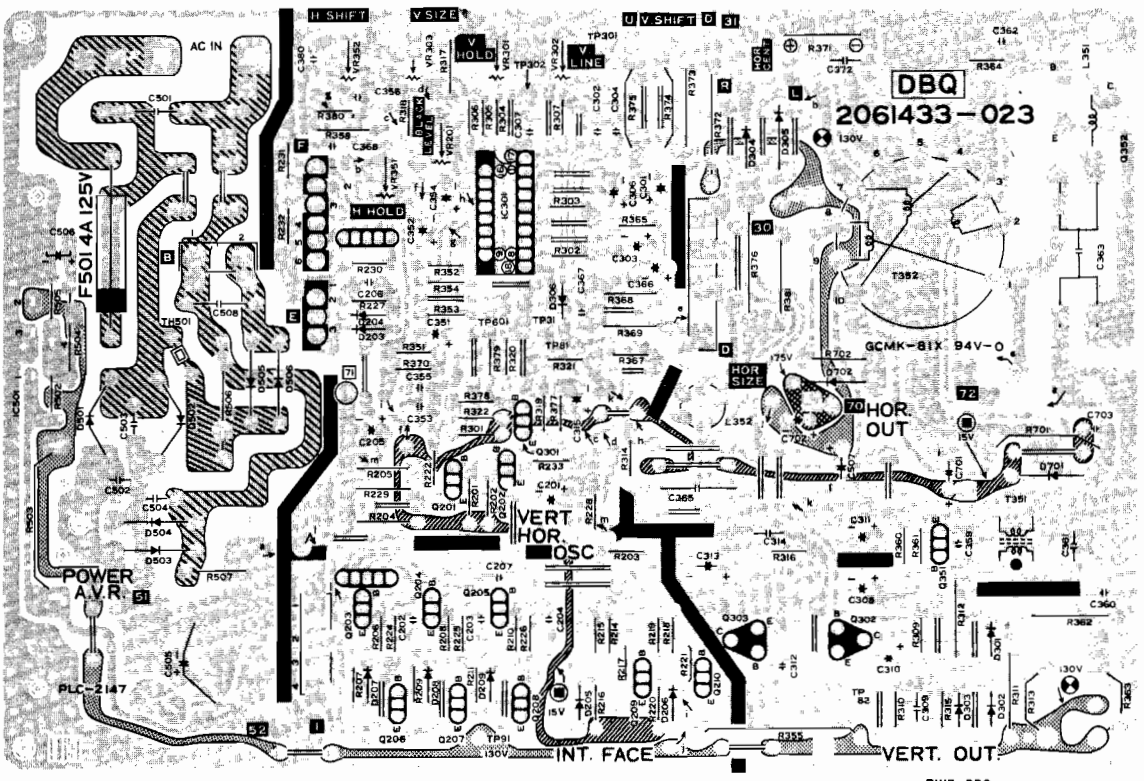

BOTTOM VIEW

FIGURE 11 MAIN P.C. BOARD

P.C. BOARD LAYOUT

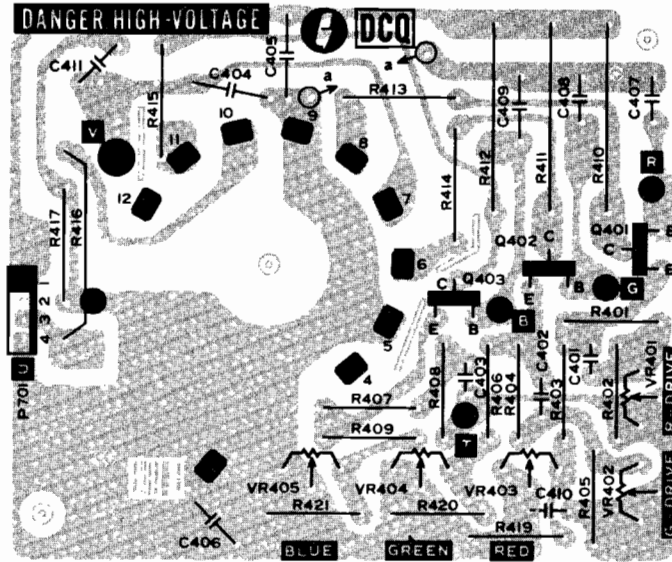

TOP VIEW

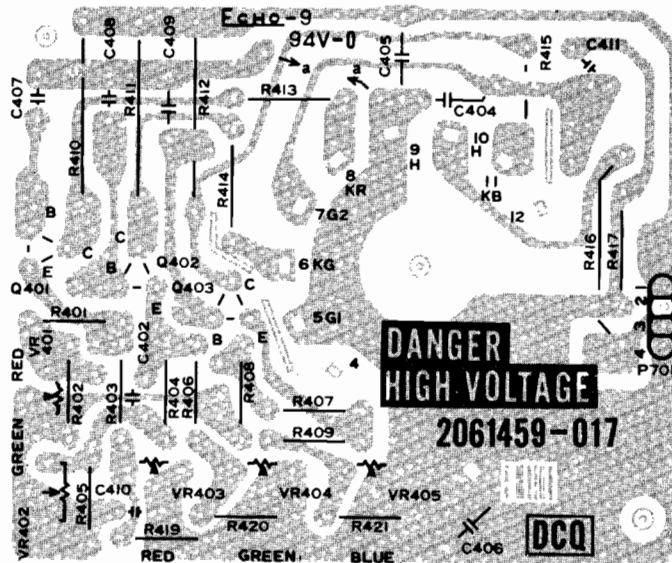

BOTTOM VIEW

FIGURE 12 NECK P.C. BOARD

MAIN BOARD (CONT.)

Ref. No.	Part No.	Description	Ref. No.	Part No.	Description
CAPACITORS (CONT.)			SEMICONDUCTORS (CONT.)		
C380	202X7200-087	470 uF, 500V Ceramic	Q206	200X3181-523	Transistor (NPN) 2SC1815GR
△ C501	203X1810-149	0.1 uF, 125V Mylar	Q207	200X3181-523	Transistor (NPN) 2SC1815GR
△ C502	202X7050-282	1500 pF, 500V Ceramic	Q208	200X3181-523	Transistor (NPN) 2SC1815GR
△ C503	202X7810-214	2200 pF, 125V Ceramic	Q209	200X3181-523	Transistor (NPN) 2SC1851GR
△ C504	202X7810-214	2200 pF, 125V Ceramic	Q210	200X3181-523	Transistor (NPN) 2SC1851GR
C505	203X0220-075	560 uF, 200V Electrolytic	Q301	200X3181-523	Transistor (NPN) 2SC1851GR
C506	203X0040-034	22 uF, 160V Electrolytic	Q302	200X3207-306	Transistor (NPN) 2SC2073LBGL2
C507	203X0041-057	47 uF, 160V Electrolytic	Q303	200X3207-306	Transistor (NPN) 2SC2073LBGL2
C701	203X0019-092	1000 uF, 25V Electrolytic	Q351	200X3248-217	Transistor (NPN) 2SC2482BK
C702	203X0634-061	10 uF, 100V Electrolytic	Q352	200X4589-802	Transistor (NPN) 2SD898B
C703	202X7050-248	1000 pF, 500V Ceramic	IC301	200X2300-033	IC HA11423
			△★ IC501	200X2600-183	IC STR381
SEMICONDUCTORS			TRANSFORMERS & COILS		
D203	201X2010-159	Diode, IS2076-27	L351	201X4710-134	Coil, (RF Choke)
D204	201X2010-159	Diode, IS2076-27	L352	201X5000-083	Coil, Horiz. Size
D205	201X2010-159	Diode, IS2076-27	L701	611X0004-007	Coil, Adg.
D206	201X2010-159	Diode, IS2076-27	T351	202X1300-080	Transformer, Hor. Drive
D207	201X2010-159	Diode, IS2076-27	△★ T352	200X9720-301	HV-Unit M-11
D208	201X2010-159	Diode, IS2076-27			
D209	201X2010-159	Diode, IS2076-27			
D301	201X2010-165	Diode, ISS81			
D302	201X2010-159	Diode, IS2076-27	△ F501	204X7120-073	Fuse, 4 Amp. 125V
D303	201X2010-159	Diode, IS2076-27	J402	206X5008-632	Recep W Wire 3P-M-BG
D304	201X2120-009	Diode, RH-IV	P201	204X9600-466	Plug, PWB 3P-J
D305	201X2120-009	Diode, RH-IV	P202	204X9601-477	Plug, PWB 6P-Q
D306	201X2010-159	Diode, IS2076-27	P401	204X9600-298	Plug, PWB 4P-B
△ D501	201X3120-216	Diode, RM-1AV	P501	204X9600-249	Plug, PWB 2P-B
△ D502	201X3120-216	Diode, RM-1AV	P601	204X9600-304	Plug, PWB 4P-C
△ D503	201X3120-216	Diode, RM-1AV	TH501	201X0100-112	Thermistor
△ D504	201X3120-216	Diode, RM-1AV			
D505	201X3120-216	Diode, RM-1AV			
D506	201X3120-216	Diode, RM-1AV			
D701	201X2130-234	Diode, RU-2V			
D702	201X2120-009	Diode, RH-1V			
Q201	200X3181-523	Transistor (NPN) 2SC1815GR			
Q202	200X3181-523	Transistor (NPN) 2SC1815GR			
Q203	200X4056-260	Transistor (PNP) 2SA562-Y-TM			
Q204	200X4056-260	Transistor (PNP) 2SA562-Y-TM			
Q205	200X4056-260	Transistor (PNP) 2SA562-Y-TM			

NECK BOARD

RESISTORS			CAPACITORS		
R401	203X6000-729	220 Ohm, 5% 1/4W Carbon	C401	202X7050-269	1200 pF, 500V Ceramic
R402	203X6500-540	390 Ohm, 5% 1/4W Carbon	C402	202X7050-248	1000 pF, 500V Ceramic
R403	203X6000-661	820 Ohm, 5% 1/4W Carbon	C403	202X7050-248	1000 pF, 500V Ceramic
R404	203X6000-729	220 Ohm, 5% 1/4W Carbon	C404	202X7050-282	1500 pF, 1.5KV Ceramic
R405	203X6500-540	390 Ohm, 5% 1/4W Carbon	C405	202X7050-483	0.01 uF, 500V Ceramic
R406	203X6000-661	820 Ohm, 5% 1/4W Carbon			
R407	203X6000-729	470 Ohm, 5% 1/4W Carbon			
R408	203X6000-998	270 Ohm, 5% 1/4W Carbon			
R409	203X6000-661	820 Ohm, 5% 1/4W Carbon	Q401	200X3206-800	Transistor (NPN) 2SC2068LB
R410	203X9104-824	15K Ohm, 5% 2W M.O. Forming	Q402	200X3206-800	Transistor (NPN) 2SC2068LB
R411	203X9104-824	15K Ohm, 5% 2W M.O. Forming	Q403	200X3206-800	Transistor (NPN) 2SC2068LB
R412	203X9104-824	15K Ohm, 5% 2W M.O. Forming			
R413	203X6000-998	2.7K Ohm, 5% 1/2W Comp.			
R414	203X6000-998	2.7K Ohm, 5% 1/2W Comp.			
R415	203X6000-998	2.7K Ohm, 5% 1/2W Comp.	J401	206X5009-296	RECEP W Wire 4P-E
R416	203X9105-154	2.2 Ohm, 5% 2W Metal Oxide	P402	204X9600-254	Plug, PWB 3P-A
R419	203X6500-741	2.7K Ohm, 5% 1/4W Carbon	P403	204X9600-981	Plug, Pin 1P-D
R420	203X6500-741	2.7K Ohm, 5% 1/4W Carbon	P701	204X9601-020	Plug, PWB 4P-E
R421	203X6500-741	2.7K Ohm, 5% 1/4W Carbon			
VR401	204X2115-014	500 Ohm, -B Semi-Fixed			
VR402	204X2115-014	500 Ohm, -B Semi-Fixed			
VR403	204X2115-006	5K Ohm, -B Semi-Fixed			
VR404	204X2115-006	5K Ohm, -B Semi-Fixed			
VR405	204X2115-006	5K Ohm, -B Semi-Fixed			

TYPICAL DC VOLTAGES

TRANSISTOR NO.	TERMINAL		
	COLLECTOR	BASE	EMITTER
Q201	8.1	0.43	0.36
Q202	9.8	8.1	9.3
Q203	0	0.35	1.0
Q204	0	0.35	1.0
Q205	0	0.35	1.0
Q206	9.7	5.5	4.8
Q207	9.7	5.5	4.8
Q208	9.7	5.5	4.8
Q209	15.4	-0.30	0.01
Q210	14.0	0.31	0.17
Q301	15.5	4.7	4.2
Q302	79	37.8	37.7
Q303	37	0.51	0
Q351	41.4	0.41	0
Q352	DO NOT MEASURE	-0.03	0
Q401	139	9.7	9.3
Q402	139	9.7	9.3
Q403	139	9.7	9.3

I.C. 301	
PIN NO.	VOLTAGE
1	1.16
2	4.0
3	6.8
4	3.9
5	12.1
6	4.1
7	4.1
8	1.9
9	12.2
10	14.2
11	3.6
12	7.9
13	6.8
14	12.8
15	1.52
16	0
17	0.83
18	0

I.C. 501	
PIN NO.	VOLTAGE
1	163
2	130
3	0
4	132

19" COLOR MONITOR SCHEMATIC DIAGRAM

MODELS 19K4901, 19K4906, 19K4951, 19K4956

Power Supply Voltage and Symbols

Symbol	Voltage	Operating Circuit
	15V	Vert. Osc. Sync Blanking CRT Cut-Off
	130V	Horiz. Osc. Horz. Drive Horz. Output Vert. Output
	175V	Video Output

★

SERVICE TECHNICIAN WARNING
X-RAY RADIATION PRECAUTION:

THIS PRODUCT CONTAINS CRITICAL ELECTRICAL AND MECHANICAL PARTS ESSENTIAL FOR X-RAY RADIATION PROTECTION.
FOR REPLACEMENT PURPOSES, USE ONLY TYPE PARTS SHOWN IN THE PARTS LIST.

⚠

CAUTION: FOR CONTINUED SAFETY, REPLACE SAFETY CRITICAL COMPONENTS ONLY WITH MANUFACTURER'S RECOMMENDED PARTS.
AVERTISSEMENT: POUR MAINTENIR LE DEGRE DE SECURITE DE L'APPAREIL NE REMPLACER LES COMPOSANTS DONT LE FONCTIONNEMENT EST CRITIQUE POUR LA SECURITE QUE PAR DES PIECES RECOMMANDEES PAR LE FABRICANT.

OSCILLOSCOPE WAVEFORM PATTERN

The waveforms shown are as observed on the wide band oscilloscope with the monitor turned to a reasonably strong signal and a normal picture. The voltages shown on each waveform are the approximate peak amplitudes.
If the waveforms are observed on the oscilloscope with a poor high frequency response, the corner of the pulses will tend to be more rounded than those shown and the amplitude of any high frequency pulse will tend to be less.

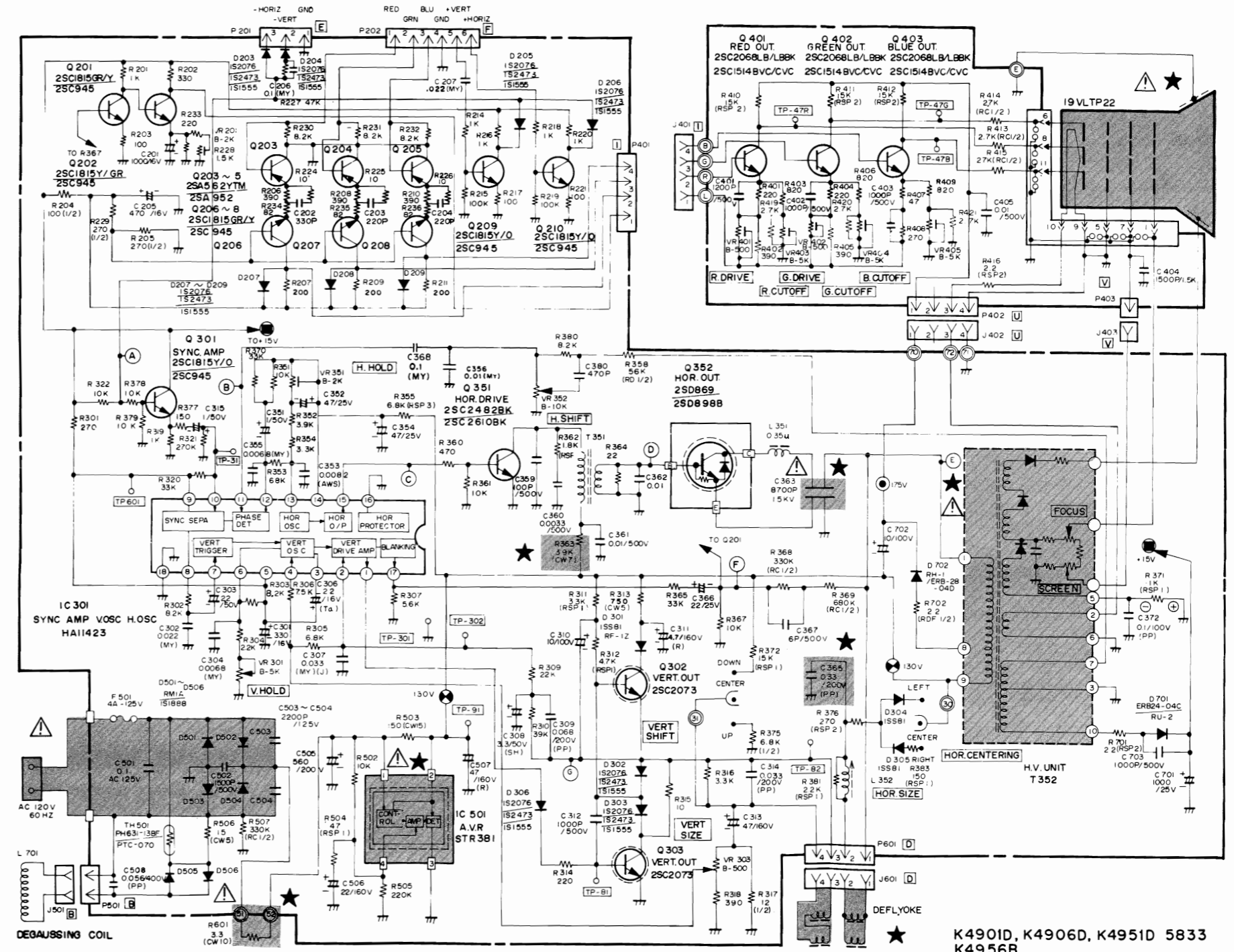
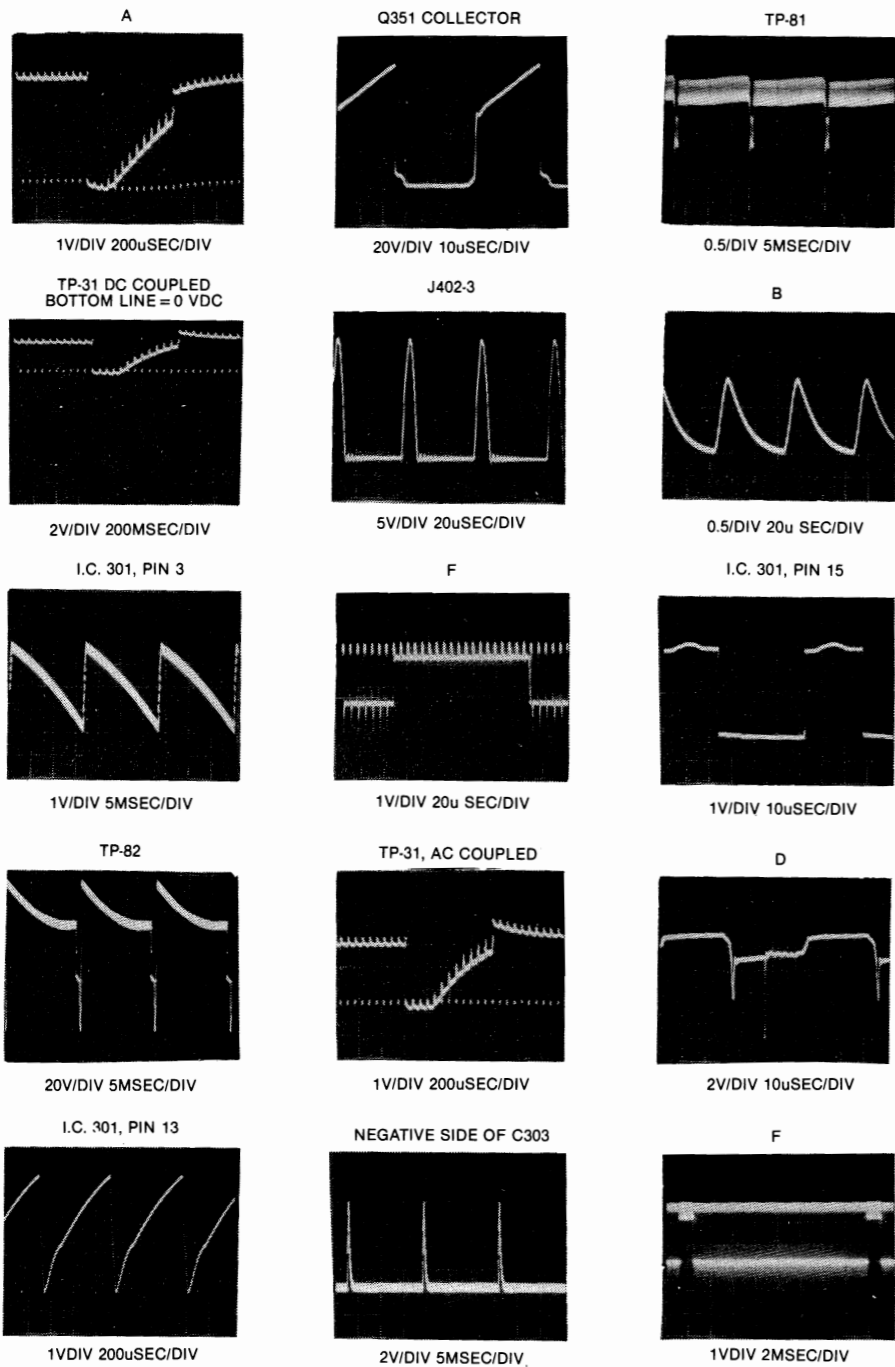

SERVICE NOTES

LIMITED WARRANTY

D. Gottlieb & Co. warrants to the initial purchaser of the D. Gottlieb & Co. machine that the items listed in the following schedule as installed and used in the original D. Gottlieb & Co. machine will for the applicable period set forth in the schedule, computed from the initial date of purchase from an authorized D. Gottlieb & Co. distributor, be free of defects in materials and workmanship:

SCHEDULE

GAME	ITEM	WARRANTY PERIOD
Pinball	All Electronic Printed circuit boards	90 days
Pinball-Video	All Electronic Printed Circuit Boards	90 days
	Card Cage	90 days
	Television Monitor	30 days
Video	All Electronic Printed Circuit Boards	90 days
	Television Monitor	30 days

This Limited Warranty does not apply to any parts damaged in the course of handling or assembling by the customer or damage due to other than normal use or use in violation of instructions or reasonable practices, or further damaged in return shipment. This Limited Warranty is made only to the original customer, and is and shall be in lieu of all other warranties expressed or implied, and of all other obligations or liabilities on the part of D. Gottlieb & Co. and in no event shall D. Gottlieb & Co. be liable for any anticipated profits, consequential damages, loss of time, or other losses incurred by the customer in connection with the purchase or operation of D. Gottlieb & Co. machines or components thereof.

The registration card with each D. Gottlieb & Co. factory-wired machine must be filled in and returned to D. Gottlieb & Co. within ten days after date of purchase for this Limited Warranty to be effective. This Limited Warranty applies only to machines so registered.

THIS LIMITED WARRANTY IS IN LIEU OF ANY OTHER EXPRESS OR IMPLIED WARRANTIES, INCLUDING ANY IMPLIED WARRANTY OF MERCHANTABILITY OR FITNESS, AND OF ANY OTHER OBLIGATION ON THE PART OF THE SELLER AND D. GOTTLIEB & CO.

 **Gottlieb**[™]
AMUSEMENT GAMES



GottliebTM AMUSEMENT GAMES

165 W. Lake Street Northlake, IL 60164
(312) 562-7400 Telex 72-8463

A Columbia Pictures Industries Company 

